

Table of contents

Table of contents	1
Synchronous servomotors	2
The construction of the series „A” motors.....	2
The construction of the series „Ai” motors	2
Selection of the motors.....	3
Calculation of the root-mean-square torque.....	3
Designation of the motor models	5
Customized motors.....	5
Brakes.....	5
Definitions of the motor technical specifications.....	5
Summing table of „A” motors.....	6
A1-54-30-EH/4096.....	7
A2-54-30-EH/4096.....	8
A3-54-30-EH/4096.....	10
A6-54-30-EH/4096.....	11
A9-54-30-EH/4096.....	13
A12-54-20-EH/4096.....	15
A22-54-20-EH/4096.....	16
A30-54-20-EH/4096.....	17
A38-54-20-EH/4096.....	18
Summing table of „Ai” motors.....	19
Ai2.5-54-40-EH/4096	20
Ai5-54-40-EH/4096	21
Ai8-54-30-EH/4096	23
Ai15-54-26-EH/4096	24
Ai28-54-25-EH/4096	26
Ai50-54-20-EH/4096	27
Ai70-54-20-EH/4096	28
Asynchronous servomotors	29
Definitions of the motor technical specifications.....	30
Summing table.....	30
AiS100LW15H.....	31
AiS100LW20H.....	32
AiS132LW15H.....	33
AMS112MW20H.....	34
AMS180SW20H	35
AMS180MW20H.....	36
AMS180LW20H.....	37
MDFKARS071-22	38
MDFKARS080-22	39
DA 132K 23 A 10-5	41
DA 132L 23 A 10-5	42
Encoders	43
Power connector.....	46
Built in holding brake.....	48
Cooling of the air cooled motors.....	50

Synchronous servomotors

NCT servomotors series „A” and „Ai” motors are developed and produced by NCT Kft., are prepared especially for the precision drive of automatic machine-tools. Thanks to the special configuration, these motors meet high level dynamic requirements of modern machine-tools, they are built for long life, and have a maintenance-free operation.



The construction of the series „A” motors

The motors are permanent magnet synchronous machine with three-phase eight pole star-connected winding on the stator, and eighth-pole rotor. The incremental or absolute-value encoder is mounted on the non drive end of the motor, which also provides information about the position of the pole-core relative to the stator winding. The stator is completely closed and the shaft extension is sealed. The cable connectors are also sealed. Thermal loss convects in a natural way -no external fan needed- so the motors are robust. Both the excitation around the boundary of the stator and the induction of the air-gap produced by the rotor are quite sinusoidal, so the torque of the motor can be exactly controlled independently of the pole-core position, because of this an extremely accurate speed control can be realized appropriately.

The construction of the series „Ai” motors

The construction of series „Ai” motors is identical to the series „A” motors except the material of the rotor magnets. Thanks to the rare earth magnets (Neodymium or Samarium-cobalt) on the rotor of the „Ai” motors they can produce much more torque in the same motor size.

Recommended field of application:

- Axle drives of machine-tools
- Spindle-drives of machine-tools
- Auxiliary drives of machining center
- Drives of single-purpose machine

- Drives of robots and manipulators
- General automatics solutions

Selection of the motors

The motors of the machine-tools should be selected according to the following two requirements:

Cutting. In this mode the determinant torque comes from the cutting force and the friction of carriage. According to a universally standard rule, it cannot be bigger than the static torque of the motor (M_0).

Rapid traverse. In this mode only the friction of carriage and the acceleration occur. The load is determined by the torque calculated from the moved mass, the required maximum speed, and the required maximum acceleration, plus the weight of the moved mass in case of vertical carriage. The calculated torque M_{rt} cannot be bigger than the maximum torque of the motor (M_{max}).

$$M_{rt} = F_{fr} \cdot \frac{v_{max}}{\omega_{max}} + m \cdot \dot{v} \cdot \frac{v_{max}}{\omega_{max}} + J \cdot \dot{\omega} + m_0 \cdot g \cdot \frac{v_{max}}{\omega_{max}} \cdot \delta$$

M_{rt}	-max torque demand of the rapid traverse
F_{fr}	-friction braking force
v_{max}	-max speed of the rapid traverse
\dot{v}	-acceleration
ω_{max}	-angular speed of the motor at v_{max}
m	-linear moved mass
m_0	-unbalanced part of the vertical moving mass
J	-moment of inertia of the rotational mass
$\dot{\omega}$	-actual value of the rotational acceleration
g	-acceleration of gravity
δ	-if it is ascensional motion $\delta = 1$, in inverse case $\delta = -1$

Calculation of the root-mean-square torque.

To determine the root-mean-square torque from the viewpoint of the motor's thermal load, the effective torque for one full load cycle should be calculated. The result is acceptable, if it is not higher than the rated torque providing that the cycle time is much smaller than the thermic time constant of the motor. In a more accurate calculation it should be considered that the acceptable constant load depends on speed and on the temperature of the motor varies as a function of load. In practice approximate calculation is suitable.

$$M_{\text{rms}} = \sqrt{\frac{1}{T} \int_0^T [M(t) \cdot E(\omega)]^2 \cdot dt} \approx \sqrt{\frac{\sum_i M_i^2 \cdot T_i}{T}}$$

- M(t)** -time function of the torque load
- E(w)** -modifying factor depend on speed
- T** -cycle time
- M_i** -torque value in the ith phase of the cycle
- T_i** -time of the ith phase of the cycle
- M_{rms}** -effective value of the torque or root-mean-square torque

The motor is suitable from the thermic point of view, if $M_{\text{rms}} < M_n$.

For example, if there are five different states in one complete cycle, then

$$M_{\text{rms}} \approx \sqrt{\frac{1}{T} (t_1 M_1^2 + t_2 M_2^2 + t_3 M_3^2 + t_4 M_4^2 + t_5 M_5^2)}$$

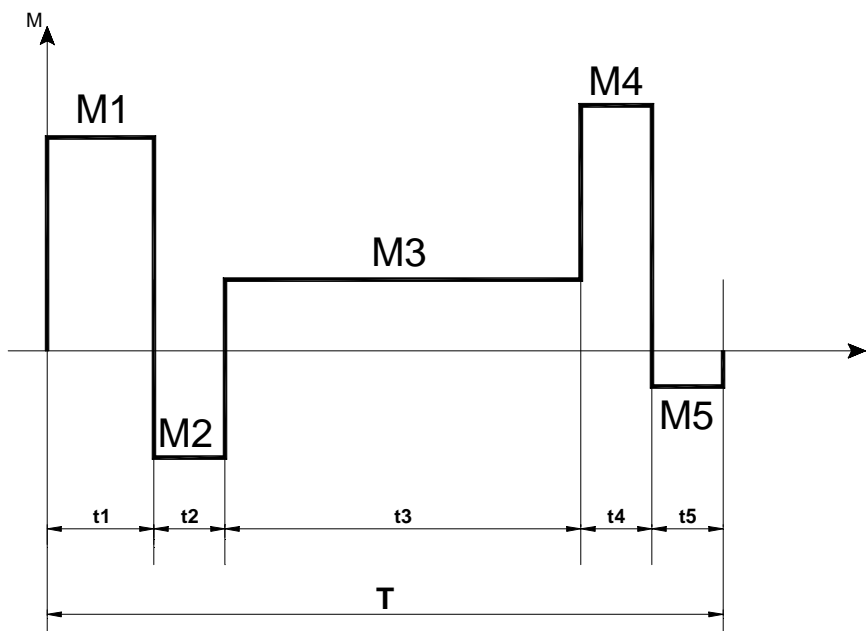

Designation of the motor models

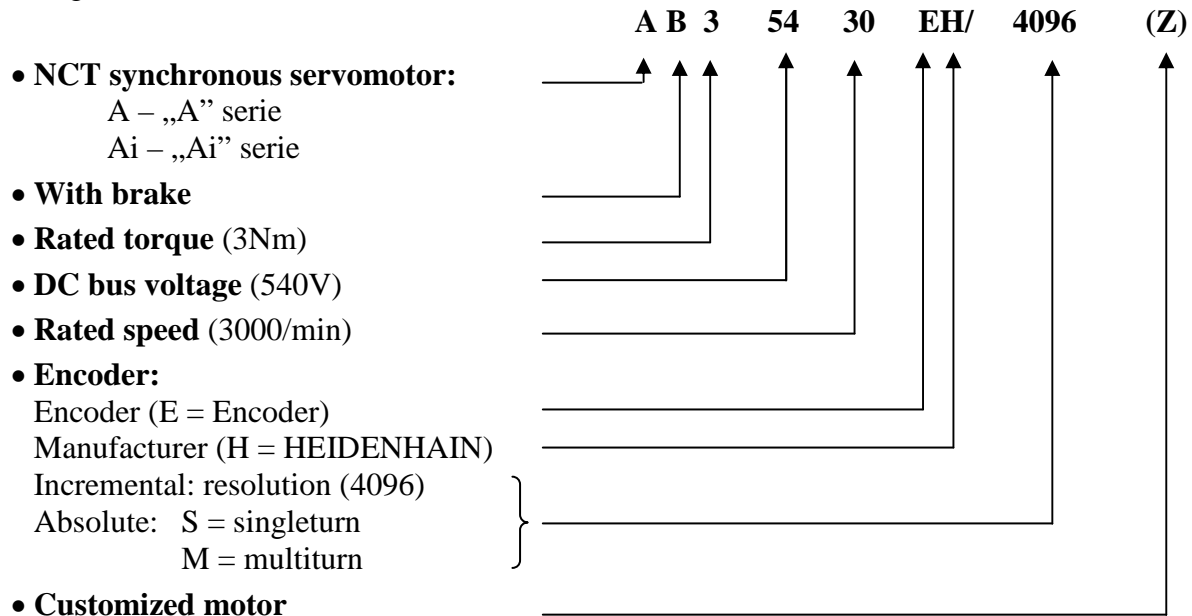

Customized motors

Motors “A” and “Ai” motors can be shipped with customized flange, special shaft extension, special winding for different voltage on demand. In this case the last character of the model designation is “Z”.

The last two characters of model designation for taper shaft motors are “Z2”.

Brakes

Holding brake (if it is available) is indicated with “B” in the model designation (for example AB3.-AB38.and AiB8 – AiB70).

Definitions of the motor technical specifications

M_0	continuous torque at zero speed
I_0	line current at M_0
P_n	rated output
M_n	rated torque
I_n	line current at M_n
n_n	rated speed
M_{max}	maximal torque
I_{max}	line current at M_{max}
n_{max}	maximal speed
K_e	voltage constant (no-load line voltage at 1000 /min.)
U_{Dcbusz}	DC bus voltage

Summing table of „A” motors

Servomotors „A” with ferrite magnets

Model	Description	Static torque	Static current	Rated speed
A1-54-30-EH/4096	A1 3000	1.1 Nm	1.0 A	3000 rpm
A1-54-30-EH/4096-Z	A1 3000 customized			
AB1-54-30-EH/4096	A1 3000 with brake			
AB1-54-30-EH/4096-Z	A1 3000 with brake, customized			
A2-54-30-EH/4096	A2 3000	2.2 Nm	2.0 A	3000 rpm
A2-54-30-EH/4096-Z	A2 3000- customized			
AB2-54-30-EH/4096	A2 3000 with brake			
AB2-54-30-EH/4096-Z	A2 3000 with brake, customized			
A3-54-30-EH/4096	A3 3000	3.0 Nm	2.5 A	3000 rpm
A3-54-30-EH/4096-Z	A3 3000 customized			
AB3-54-30-EH/4096	A3 3000 with brake			
AB3-54-30-EH/4096-Z	A3 3000 with brake, customized			
A6-54-30-EH/4096	A6 3000	6.0 Nm	4.5 A	3000 rpm
A6-54-30-EH/4096-Z	A6 3000 customized			
AB6-54-30-EH/4096	A6 3000 with brake			
AB6-54-30-EH/4096-Z	A6 3000 with brake, customized			
A9-54-30-EH/4096	A9 3000	9.0 Nm	6.0 A	3000 rpm
A9-54-30-EH/4096-Z	A9 3000 customized			
AB9-54-30-EH/4096	A9 3000 with brake			
AB9-54-30-EH/4096-Z	A9 3000 with brake, customized			
A12-54-20-EH/4096	A12 2000	12.0 Nm	8.8 A	2000 rpm
A12-54-20-EH/4096-Z	A12 2000 customized			
AB12-54-20-EH/4096	A12 2000 with brake			
AB12-54-20-EH/4096-Z	A12 2000 with brake, customized			
A22-54-20-EH/4096	A22 2000	22.0 Nm	15.0 A	2000 rpm
A22-54-20-EH/4096-Z	A22 2000 customized			
AB22-54-20-EH/4096	A22 2000 with brake			
AB22-54-20-EH/4096-Z	A22 2000 with brake, customized			
A30-54-20-EH/4096	A30 2000	30.0 Nm	19.5 A	2000 rpm
A30-54-20-EH/4096-Z	A30 2000 customized			
AB30-54-20-EH/4096	A30 2000 with brake			
AB30-54-20-EH/4096-Z	A30 2000 with brake, customized			
A38-54-20-EH/4096	A38 2000	38 Nm	18.0 A	2000 rpm
A38-54-20-EH/4096-Z	A38 2000 customized			
AB38-54-20-EH/4096	A38 2000 with brake			
AB38-54-20-EH/4096-Z	A38 2000 with brake, customized			

A1-54-30-EH/4096

A1-54-30-EH/4096-Z AB1-54-30-EH/4096 AB1-54-30-EH/4096-Z

Static torque, M_0	1.1 Nm
Static current, I_0	1.0 A
Rated output, P_n	310 W
Rated torque, M_n	1.0 Nm
Rated current, I_n	0.9 A
Rated speed, n_n	3000 /min
Maximum torque, M_{max}	2.2 Nm
Maximum current, I_{max}	2.5 A
Maximum speed, n_{max}	3200 /min
Voltage constant, K_e	71V/(1000/min)
DC bus voltage, U_{Dcbusz}	540 V
Moment of inertia (without brake), J	4 Kgcm ²
Mass (without/with brake), m	3/3.8 Kg
Line resistance, R	37.3 Ω
Protection class	IP55
Insulation class	F
Incremental encoder/resolution	ERN1326/4096
Absolute encoder Single/Multiturn	ECN1325/EQN1337
Brake	Available

NCT A1 cylindrical shaft

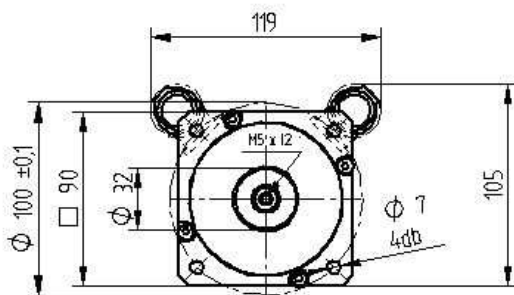

NCT A1 cylindrical shaft, with brake

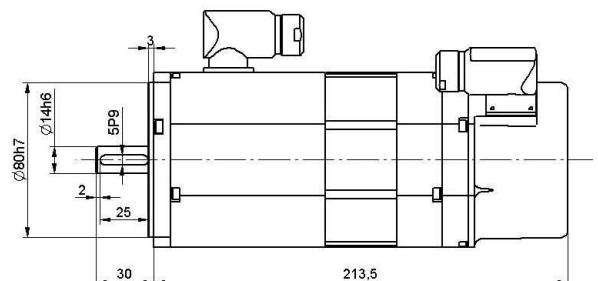
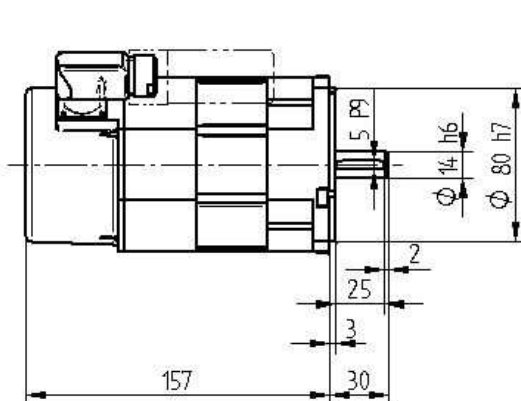
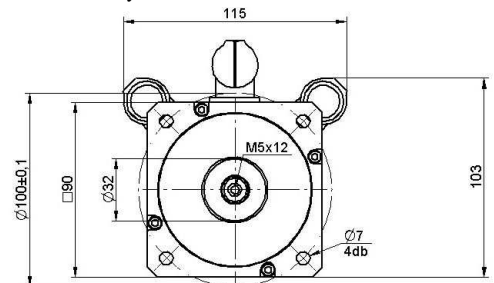

NCT A2 cylindrical shaft

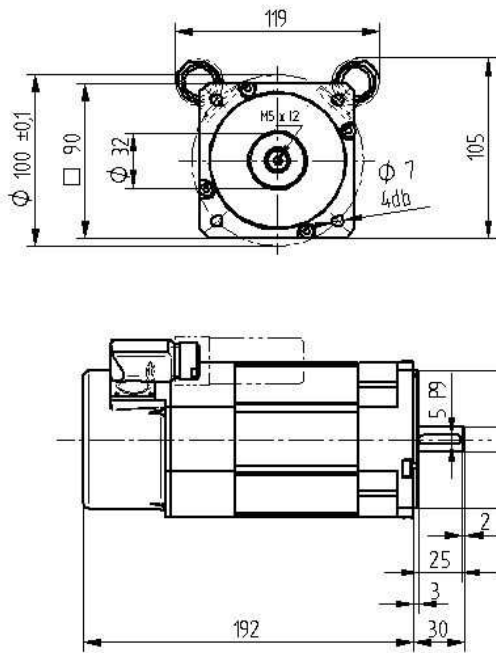

NCT A2 cylindrical shaft with brake

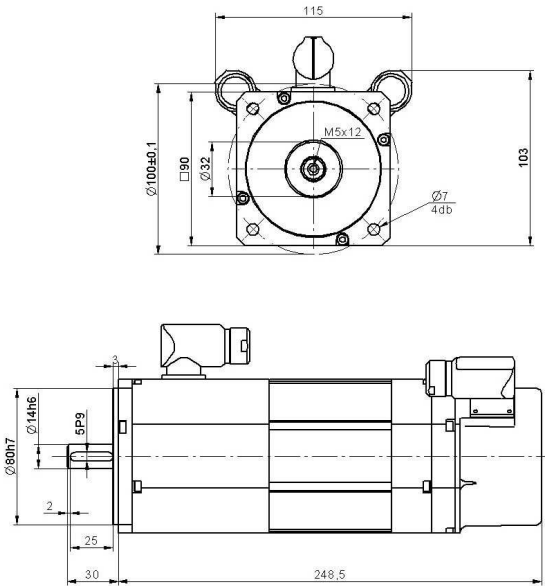

NCT A2 taper shaft

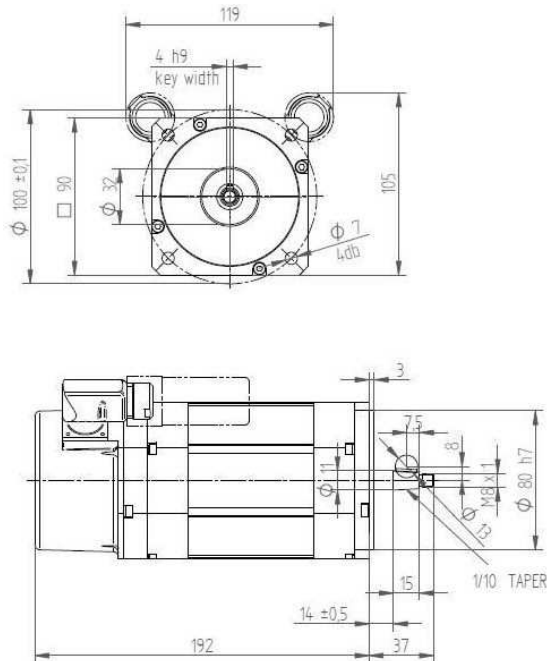

NCT A2 taper shaft with brake

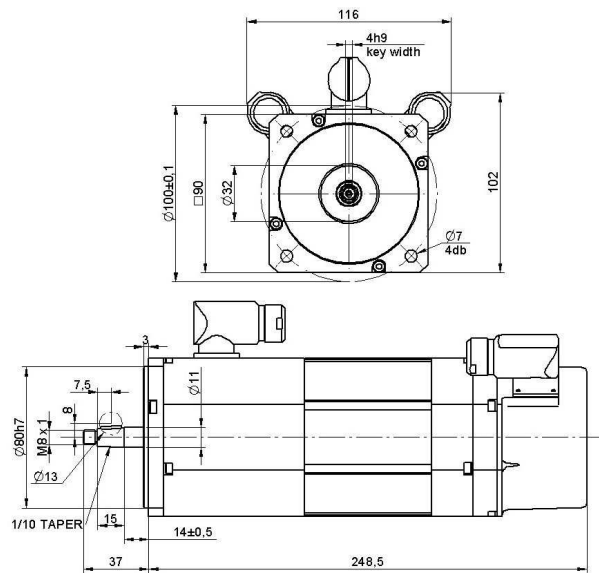

A3-54-30-EH/4096

A3-54-30-EH/4096-Z AB3-54-30-EH/4096 AB3-54-30-EH/4096-Z

Static torque, M_0	3.0 Nm
Static current, I_0	2.5 A
Rated output, P_n	720 W
Rated torque, M_n	2.3 Nm
Rated current, I_n	1.9 A
Rated speed, n_n	3000 /min
Maximum torque, M_{max}	6.0 Nm
Maximum current, I_{max}	6.2A
Maximum speed, n_{max}	3200 /min
Voltage constant, K_e	90V/(1000/min)
DC bus voltage, U_{DCbusz}	540 V
Moment of inertia (without brake), J	16 Kgcm ²
Mass, m	7.5 Kg
Mass with brake, m	11 Kg
Line resistance, R	9.5 Ω
Protection class	IP55
Insulation class	F
Incremental encoder/resolution	ERN1326/4096
Absolute encoder Single/Multiturn	ECN1325/EQN1337
Brake	Available

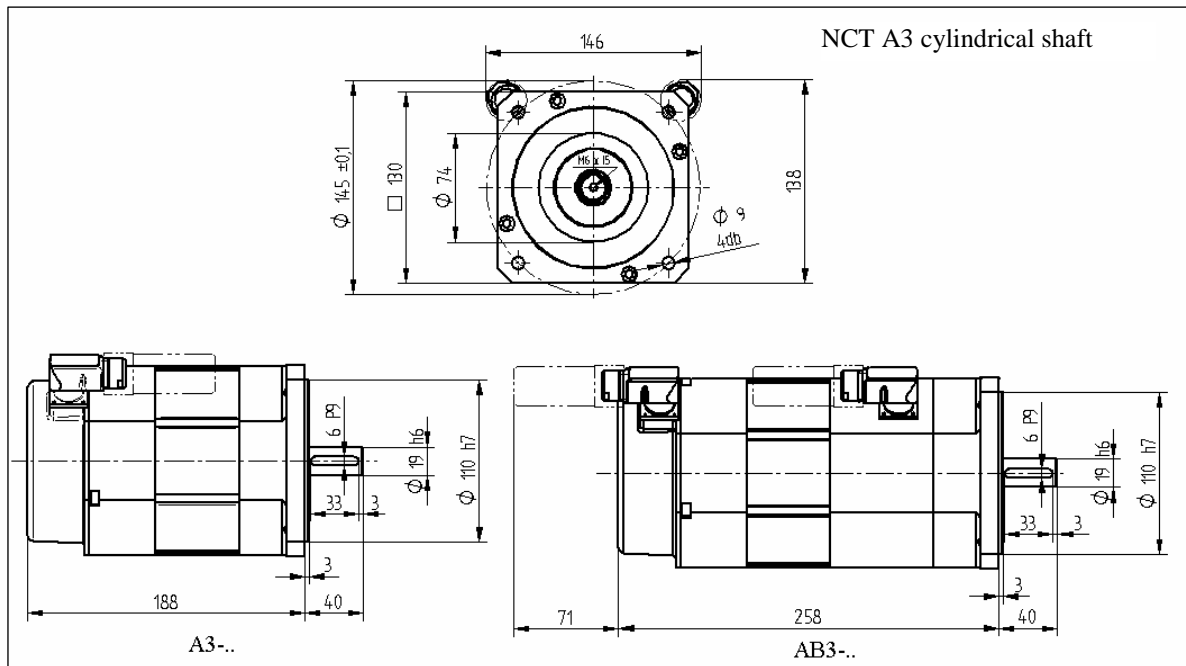

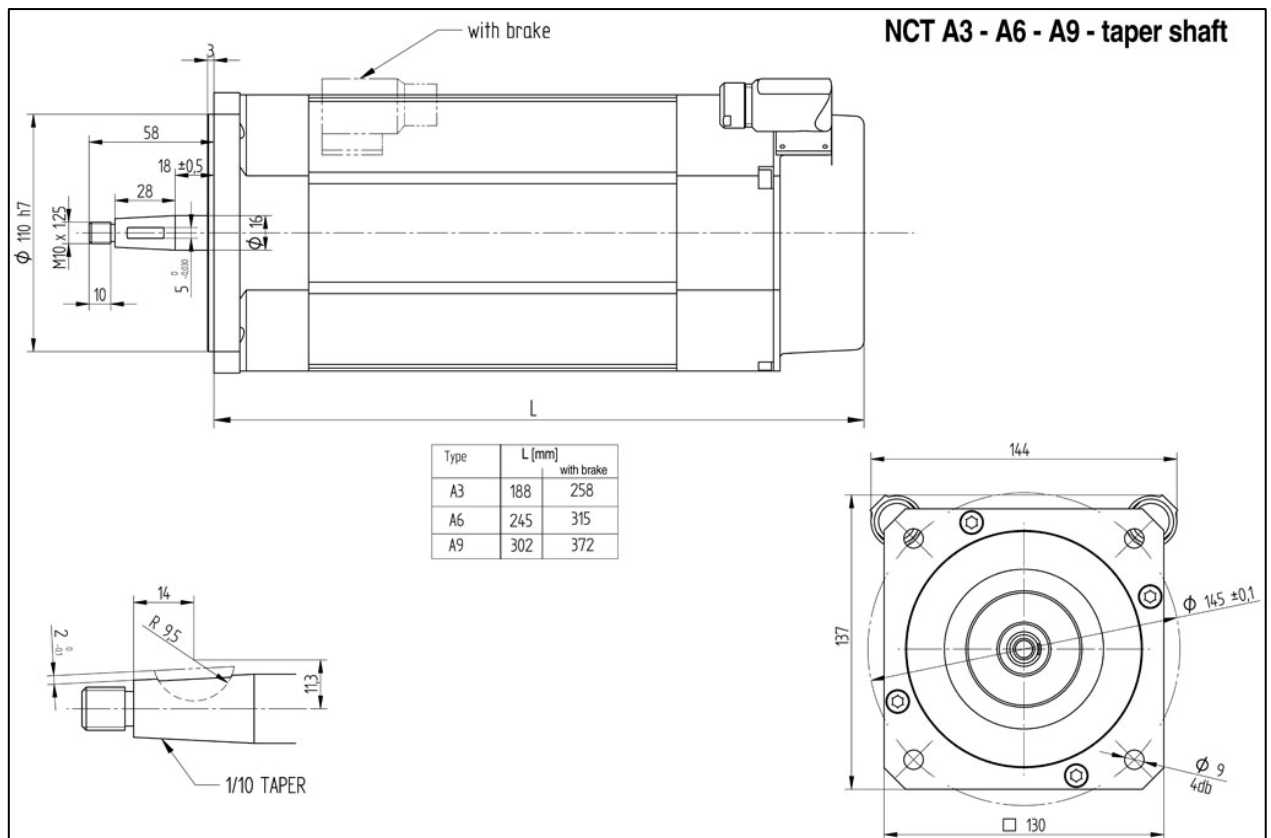

A6-54-30-EH/4096

A6-54-30-EH/4096-Z AB6-54-30-EH/4096 AB6-54-30-EH/4096-Z

Static torque, M_0	6.0 Nm
Static current, I_0	4.5 A
Rated output, P_n	1440 W
Rated torque, M_n	4.6 Nm
Rated current, I_n	3.5 A
Rated speed, n_n	3000 /min
Maximum torque, M_{max}	12.0 Nm
Maximum current, I_{max}	11.0 A
Maximum speed, n_{max}	3200 /min
Voltage constant, K_e	95V/(1000/min)
DC bus voltage, U_{DCbusz}	540 V
Moment of inertia (without brake), J	32 Kgcm ²
Mass, m	12 Kg
Mass with brake, m	15.5 Kg
Line resistance, R	3.6 Ω
Protection class	IP55
Insulation class	F
Incremental encoder/resolution	ERN1326/4096
Absolute encoder Single/Multiturn	ECN1325/EQN1337
Brake	Available

A9-54-30-EH/4096

A9-54-30-EH/4096-Z AB9-54-30-EH/4096 AB9-54-30-EH/4096-Z

Static torque, M_0	9.0 Nm
Static current, I_0	6.0 A
Rated output, P_n	2170 W
Rated torque, M_n	6.9 Nm
Rated current, I_n	4.6 A
Rated speed, n_n	3000 /min
Maximum torque, M_{max}	18 Nm
Maximum current, I_{max}	15.0 A
Maximum speed, n_{max}	3200 /min
Voltage constant, K_e	95V/(1000/min)
DC bus voltage, U_{DCbusz}	540 V
Moment of inertia (without brake), J	47.6 Kgcm ²
Mass, m	16.5 Kg
Mass with brake, m	20 Kg
Line resistance, R	2.1 Ω
Protection class	IP55
Insulation class	F
Incremental encoder/resolution	ERN1326/4096
Absolute encoder Single/Multiturn	ECN1325/EQN1337
Brake	Available

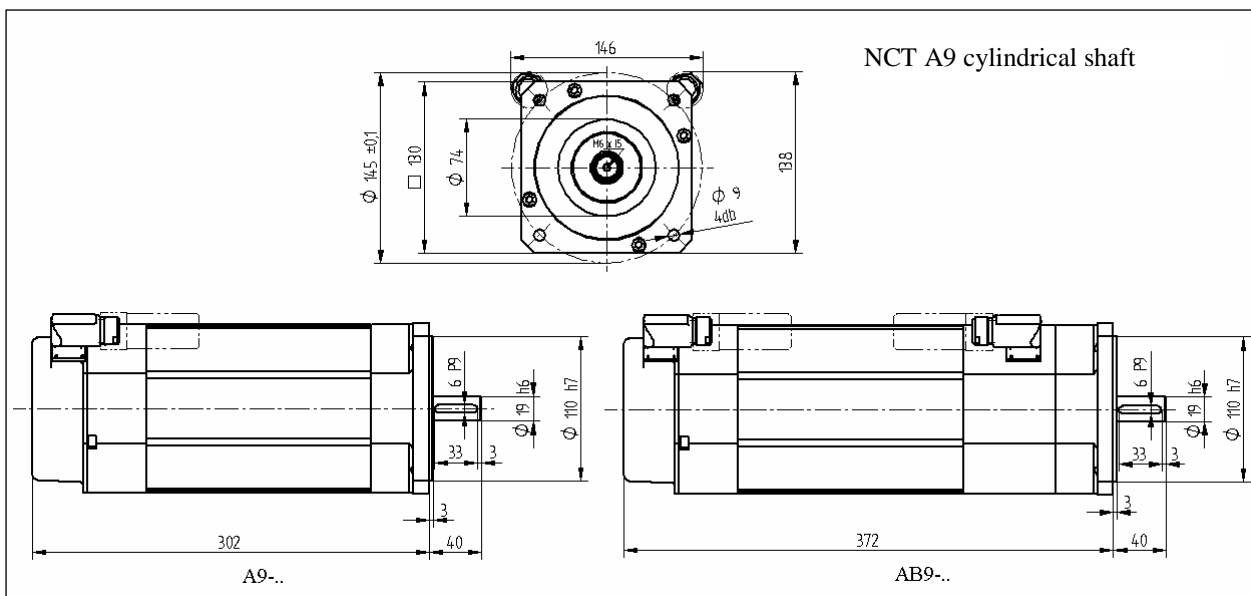

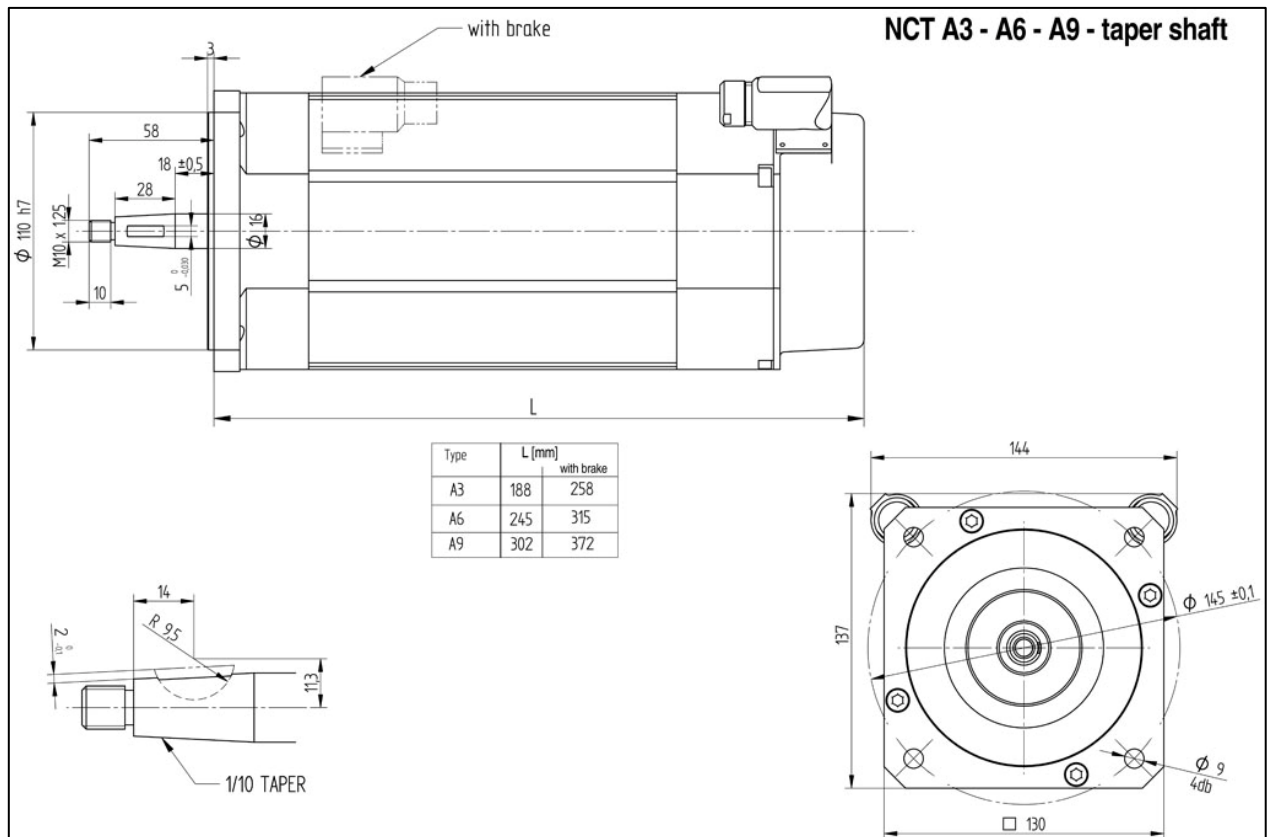

A12-54-20-EH/4096

A12-54-20-EH/4096-Z AB12-54-20-EH/4096 AB12-54-20-EH/4096-Z

Static torque, M_0	12.0 Nm
Static current, I_0	8.8 A
Rated output, P_n	1890 W
Rated torque, M_n	9 Nm
Rated current, I_n	6.6 A
Rated speed, n_n	2000 /min
Maximum torque, M_{max}	27 Nm
Maximum current, I_{max}	24 A
Maximum speed, n_{max}	3000 /min
Voltage constant, K_e	90V/(1000/min)
DC bus voltage, U_{Dcbusz}	540 V
Moment of inertia (without brake), J	64 Kgcm ²
Mass, m	18 Kg
Mass with brake, m	21 Kg
Line resistance, R	1.31 Ω
Protection class	IP55
Insulation class	F
Incremental encoder/resolution	ERN1326/4096
Absolute encoder Single/Multiturn	ECN1325/EQN1337
Brake	Available

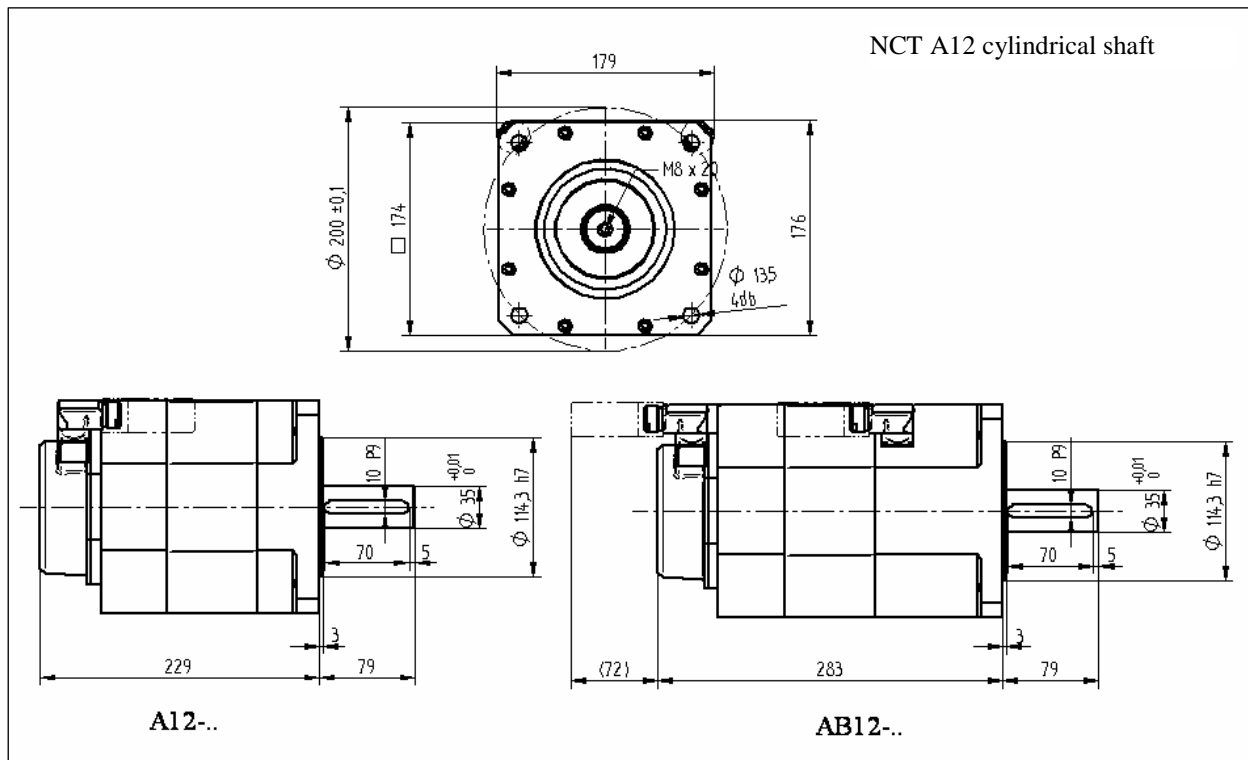

A22-54-20-EH/4096

A22-54-20-EH/4096-Z AB22-54-20-EH/4096 AB22-54-20-EH/4096-Z

Static torque, M_0	22 Nm
Static current, I_0	15 A
Rated output, P_n	3380 W
Rated torque, M_n	16.1 Nm
Rated current, I_n	11 A
Rated speed, n_n	2000 /min
Maximum torque, M_{max}	47 Nm
Maximum current, I_{max}	36 A
Maximum speed, n_{max}	3000 /min
Voltage constant, K_e	90V/(1000/min)
DC bus voltage, U_{DCbusz}	540 V
Moment of inertia (without brake), J	124 Kgcm ²
Mass, m	30 Kg
Mass with brake, m	33 Kg
Line resistance, R	0.49 Ω
Protection class	IP55
Insulation class	F
Incremental encoder/resolution	ERN1326/4096
Absolute encoder Single/Multiturn	ECN1325/EQN1337
Brake	Available

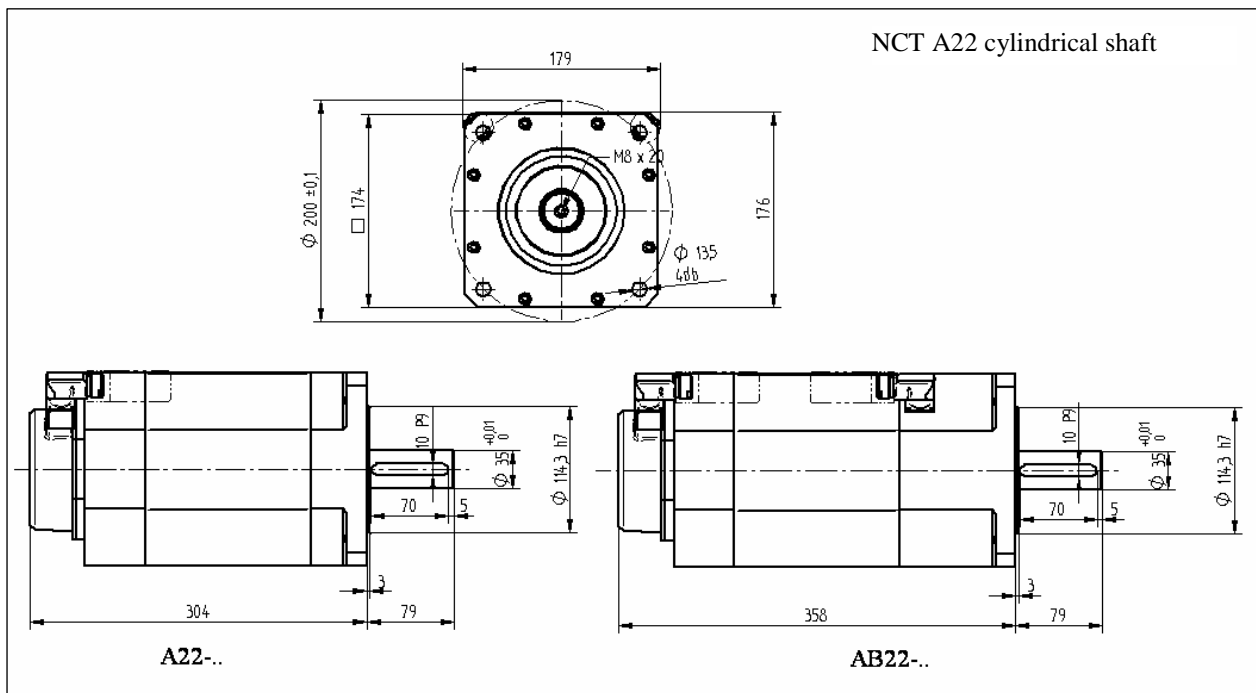

A30-54-20-EH/4096

A30-54-20-EH/4096-Z AB30-54-20-EH/4096 AB30-54-20-EH/4096-Z

Static torque, M_0	30 Nm
Static current, I_0	19.5 A
Rated output, P_n	4190 W
Rated torque, M_n	20 Nm
Rated current, I_n	13 A
Rated speed, n_n	2000 /min
Maximum torque, M_{max}	66 Nm
Maximum current, I_{max}	48 A
Maximum speed, n_{max}	3000 /min
Voltage constant, K_e	93V/(1000/min)
DC bus voltage, U_{DCbusz}	540 V
Moment of inertia (without brake), J	147.6 Kgcm ²
Mass, m	43 Kg
Mass with brake, m	46 Kg
Line resistance, R	0.296 Ω
Protection class	IP55
Insulation class	F
Incremental encoder/resolution	ERN1326/4096
Absolute encoder Single/Multiturn	ECN1325/EQN1337
Brake	Available

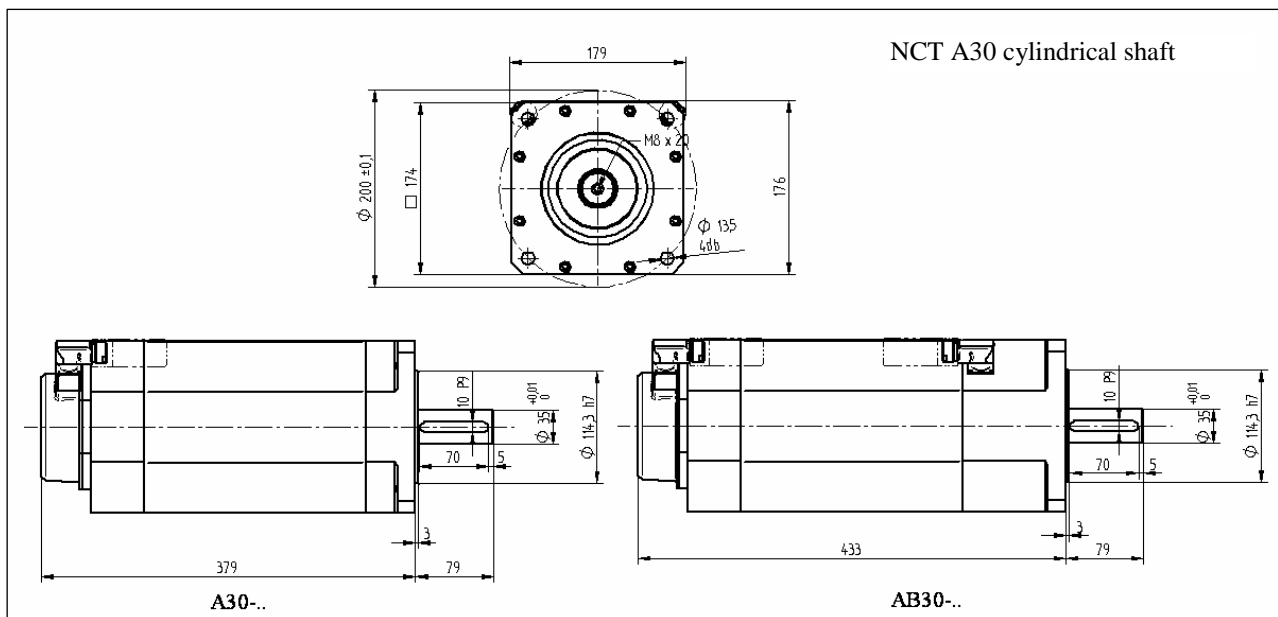

A38-54-20-EH/4096

A38-54-20-EH/4096-Z AB38-54-20-EH/4096 AB38-54-20-EH/4096-Z

Static torque, M_0	38 Nm
Static current, I_0	188 A
Rated output, P_n	5230 W
Rated torque, M_n	25 Nm
Rated current, I_n	11.8 A
Rated speed, n_n	2000 /min
Maximum torque, M_{max}	76 Nm
Maximum current, I_{max}	42 A
Maximum speed, n_{max}	2200 /min
Voltage constant, K_e	135V/(1000/min)
DC bus voltage, U_{DCbusz}	540 V
Moment of inertia (without brake), J	224 Kgcm ²
Mass, m	56 Kg
Mass with brake, m	59 Kg
Line resistance, R	0.483 Ω
Protection class	IP55
Insulation class	F
Incremental encoder/resolution	ERN1326/4096
Absolute encoder Single/Multiturn	ECN1325/EQN1337
Brake	Available

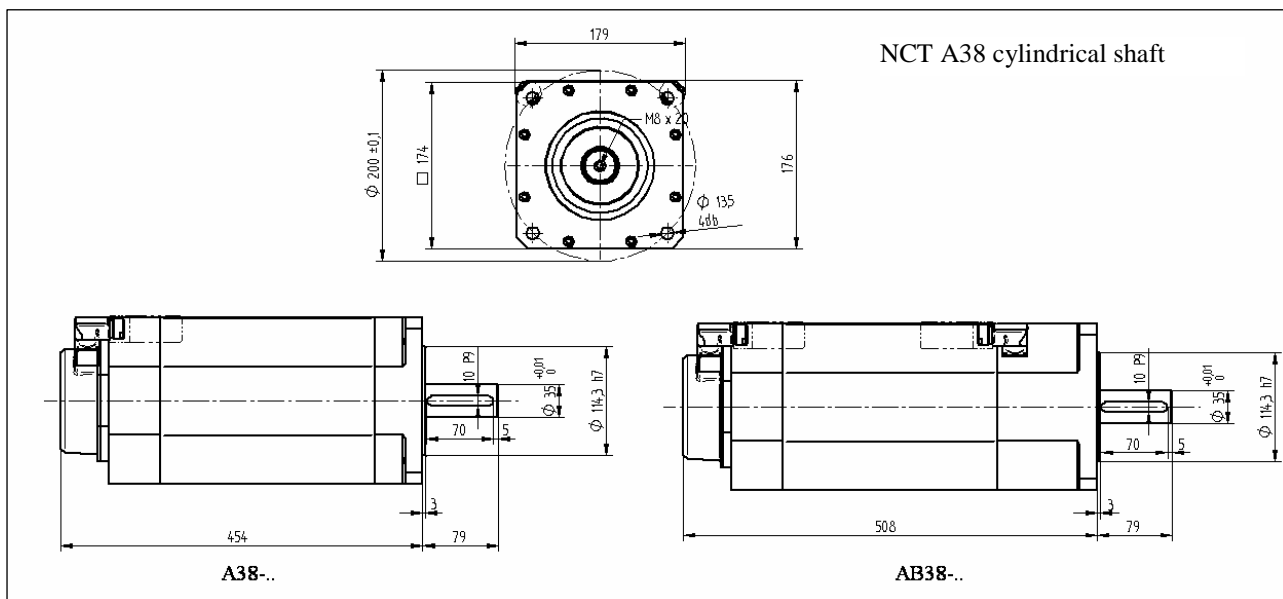

Summing table of „Ai” motors

Servomotors „Ai” with rare earth magnets

Model	Description	Size	Static torque	Static current	Reted speed
Ai2.5-54-40-EH/4096	Ai2.5 4000	A1	2.5 Nm	2.3 A	4000 rpm
Ai2.5-54-40-EH/4096-Z	Ai2.5 4000 customized				
AiB2.5-54-40-EH/4096	Ai2.5 4000 with brake				
AiB2.5-54-40-EH/4096-Z	Ai2.5 4000 with brake, customized				
Ai5-54-40-EH/4096	Ai5 4000	A2	5.0 Nm	4.6 A	4000 rpm
Ai5-54-40-EH/4096-Z	Ai5 4000 customized				
AiB5-54-40-EH/4096	Ai5 4000 with brake				
AiB5-54-40-EH/4096-Z	Ai5 4000 with brake, customized				
Ai8-54-30-EH/4096	Ai8 3000	A3	8.4 Nm	7.1 A	3000 rpm
Ai8-54-30-EH/4096-Z	Ai8 3000 customized				
AiB8-54-30-EH/4096	Ai8 3000 with brake				
AiB8-54-30-EH/4096-Z	Ai8 3000 with brake, customized				
Ai15-54-26-EH/4096	Ai15 2600	A6	17.0 Nm	13.0 A	2600 rpm
Ai15-54-26-EH/4096-Z	Ai15 2600 customized				
AiB15-54-26-EH/4096	Ai15 2600- with brake				
AiB15-54-26-EH/4096-Z	Ai15 2600 with brake, customized				
Ai28-54-25-EH/4096	Ai28 2500	A12	29.0 Nm	18.8 A	2500 rpm
Ai28-54-25-EH/4096-Z	Ai28 2500 customized				
AiB28-54-25-EH/4096	Ai28 2500 with brake				
AiB28-54-25-EH/4096-Z	Ai28 2500 with brake, customized				
Ai50-54-20-EH/4096	Ai50 2000	A22	51.0 Nm	32.6 A	2000 rpm
Ai50-54-20-EH/4096-Z	Ai50 2000 customized				
AiB50-54-20-EH/4096	Ai50 2000 with brake				
AiB50-54-20-EH/4096-Z	Ai50 2000 with brake, customized				
Ai70-54-20-EH/4096	Ai70 2000	A30	70.0 Nm	40.0 A	2000 rpm
Ai70-54-20-EH/4096-Z	Ai70 2000-as, customized				
AiB70-54-20-EH/4096	Ai70 2000 with brake				
AiB70-54-20-EH/4096-Z	Ai70 2000 with brake, customized				

Ai2.5-54-40-EH/4096

Ai2.5-54-40-EH/4096-Z

Static torque, M_0	2.5 Nm
Static current, I_0	2.3 A
Rated output, P_n	550 W
Rated torque, M_n	1.3 Nm
Rated current, I_n	1.2 A
Rated speed, n_n	4000/min
Maximum torque, M_{max}	10.5 Nm
Maximum current, I_{max}	11 A
Maximum speed, n_{max}	5000/min
Voltage constant, K_e	73 V/(1000/min)
DC bus voltage, U_{Dcbusz}	540 V
Moment of inertia (without brake), J	4 kgcm ²
Mass (without/with brake), m	3/3.8 kg
Line resistance, R	8.73 Ω
Protection class	IP55
Insulation class	F
Incremental encoder/resolution	ERN1326/4096
Absolute encoder Single/Multiturn	ECN1325/EQN1337
Brake	Available

NCT Ai2.5 cylindrical shaft

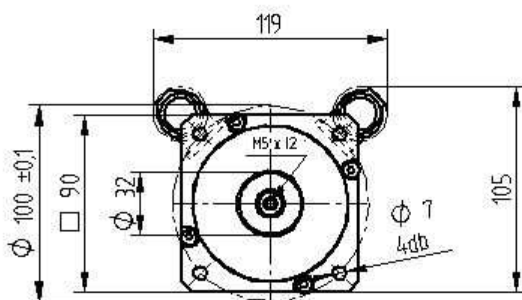

NCT Ai2.5 cylindrical shaft with brake

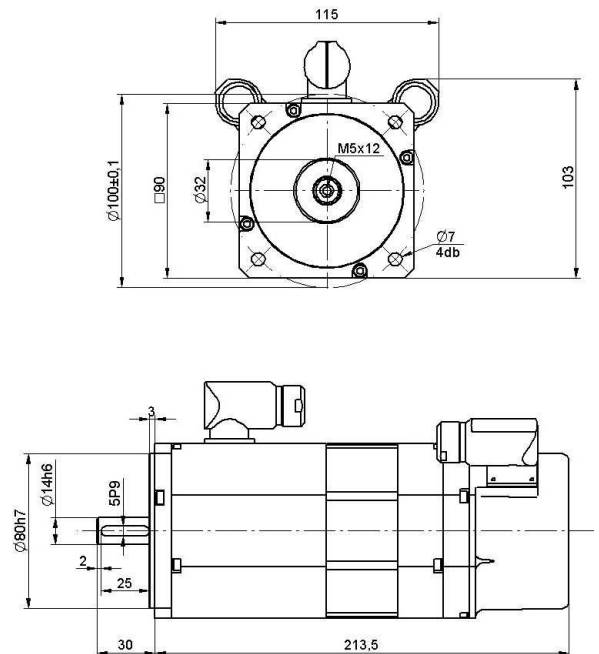

NCT Ai2.5 taper shaft

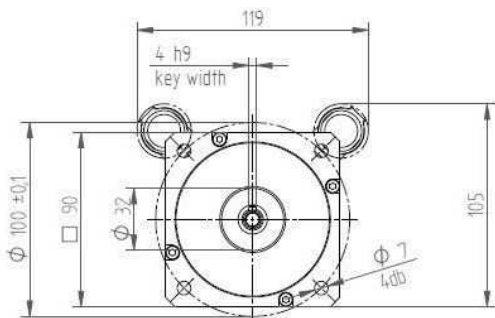

NCT Ai2.5 taper shaft with brake

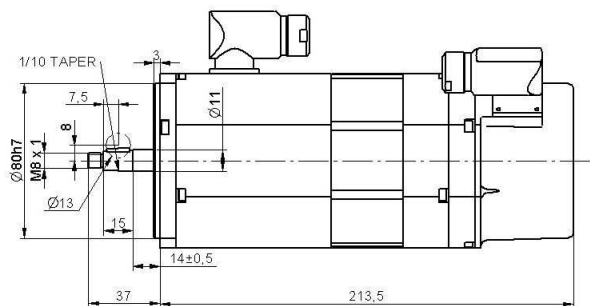
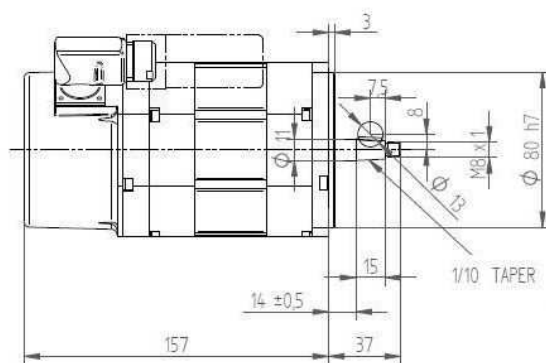
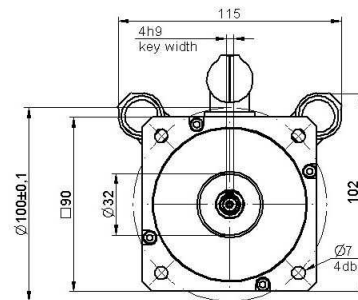

Ai5-54-40-EH/4096

Ai5-54-40-EH/4096-Z

Static torque, M_0	5 Nm
Static current, I_0	4.6 A
Rated output, P_n	1100 W
Rated torque, M_n	2.6 Nm
Rated current, I_n	2.4 A
Rated speed, n_n	3000/min
Maximum torque, M_{max}	38 Nm
Maximum current, I_{max}	33,5 A
Maximum speed, n_{max}	4500/min
Voltage constant, K_e	73V/(1000/min)
DC bus voltage, U_{Dcbusz}	540 V
Moment of inertia (without brake), J	7.0 kgcm ²
Mass (without/with brake), m	4/4.8 kg
Line resistance, R	3.05 Ω
Protection class	IP55
Insulation class	F
Incremental encoder/resolution	ERN1326/4096
Absolute encoder Single/Multiturn	ECN1325/EQN1337
Brake	Available

NCT Ai5 cylindrical shaft

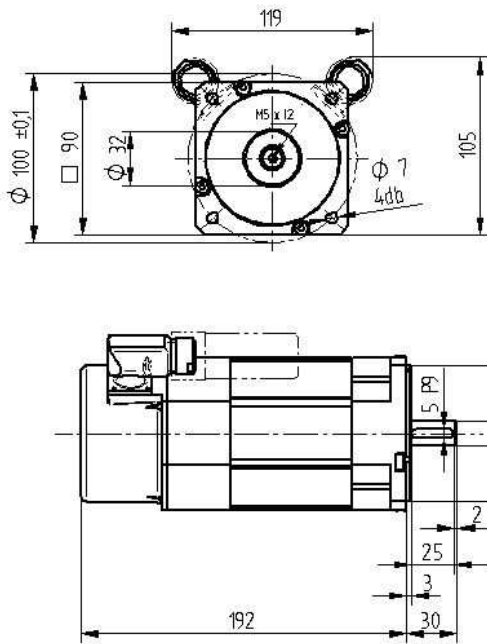

NCT Ai5 cylindrical shaft with brake

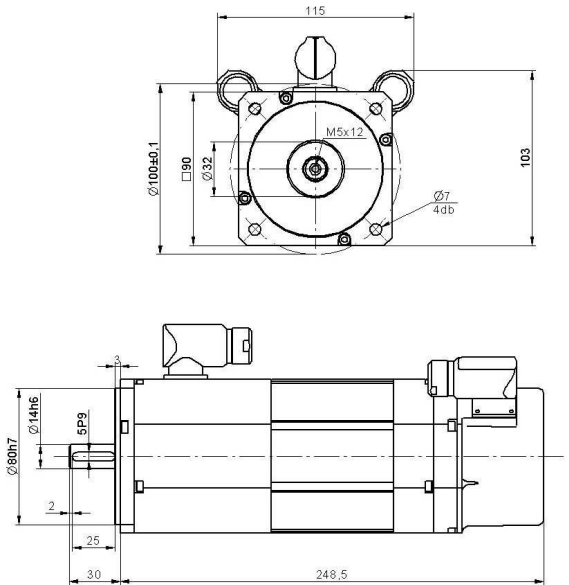

NCT Ai5 taper shaft

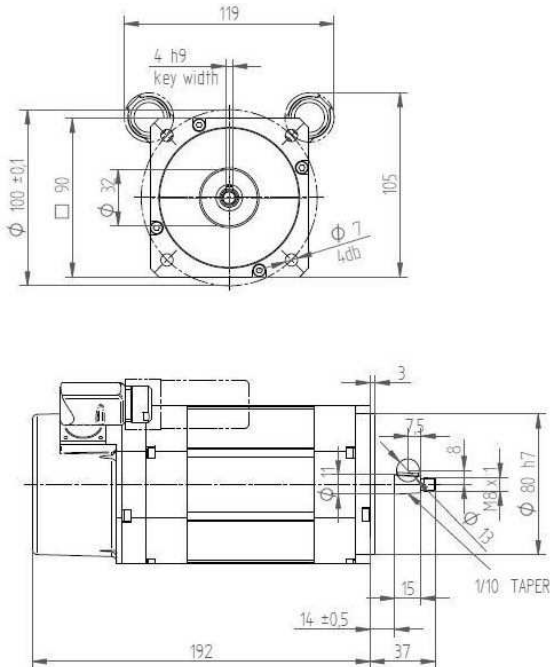

NCT Ai5 taper shaft with brake

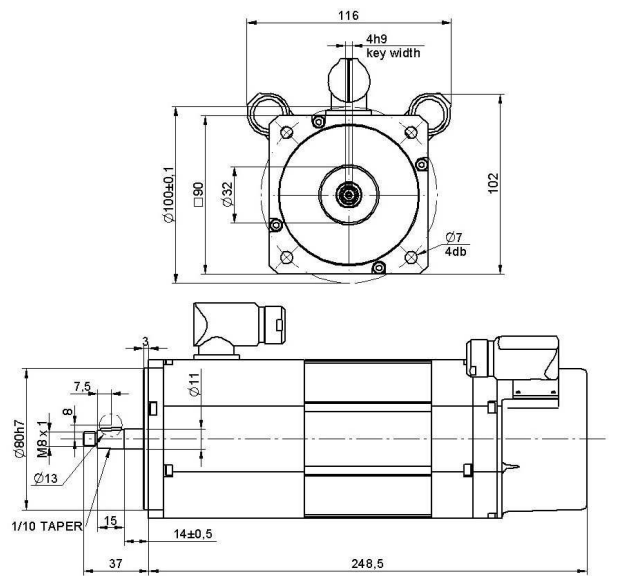

Ai8-54-30-EH/4096

Ai8-54-30-EH/4096-Z AiB8-54-30-EH/4096 AiB8-54-30-EH/4096-Z

Static torque, M_0	8.4 Nm
Static current, I_0	7.1 A
Rated output, P_n	1800 W
Rated torque, M_n	5.8 Nm
Rated current, I_n	5.2 A
Rated speed, n_n	3000/min
Maximum torque, M_{max}	38 Nm
Maximum current, I_{max}	33.5 A
Maximum speed, n_{max}	4500/min
Voltage constant, K_e	77.5V/(1000/min)
DC bus voltage, U_{DCbusz}	540 V
Moment of inertia (without brake), J	16 kgcm ²
Mass, m	7.5 kg
Mass with brake, m	11 kg
Line resistance, R	1.278 Ω
Protection class	IP55
Insulation class	F
Incremental encoder/resolution	ERN1326/4096
Absolute encoder Single/Multiturn	ECN1325/EQN1337
Brake	Available

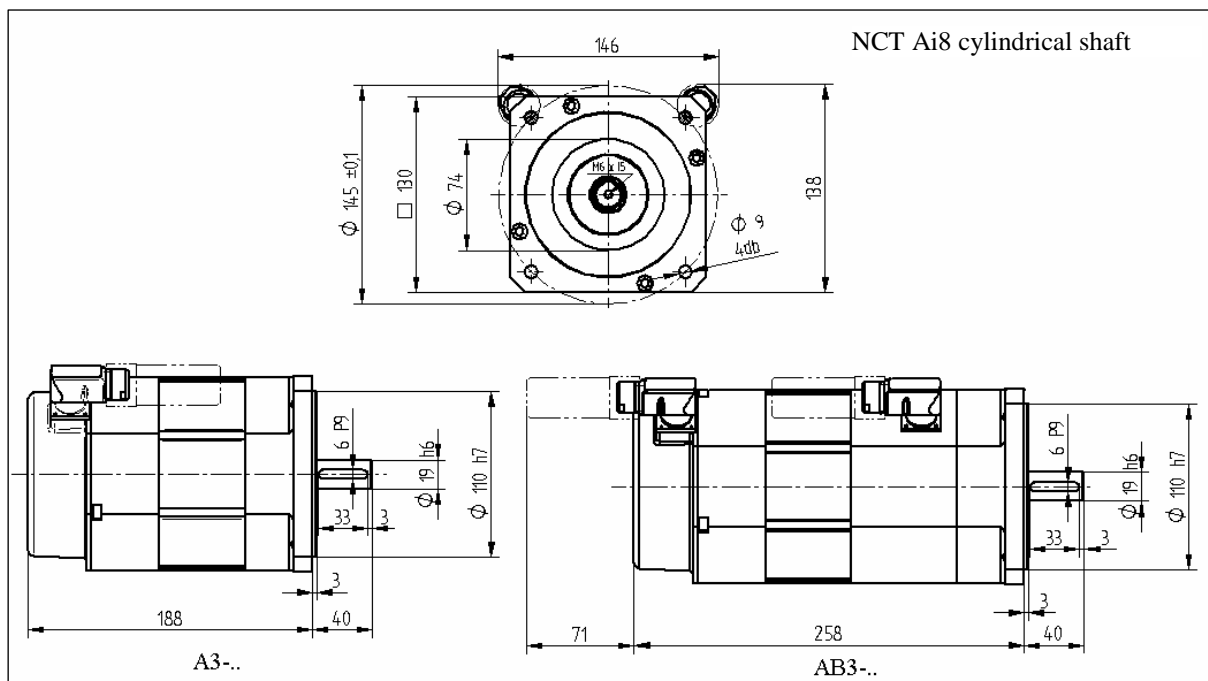

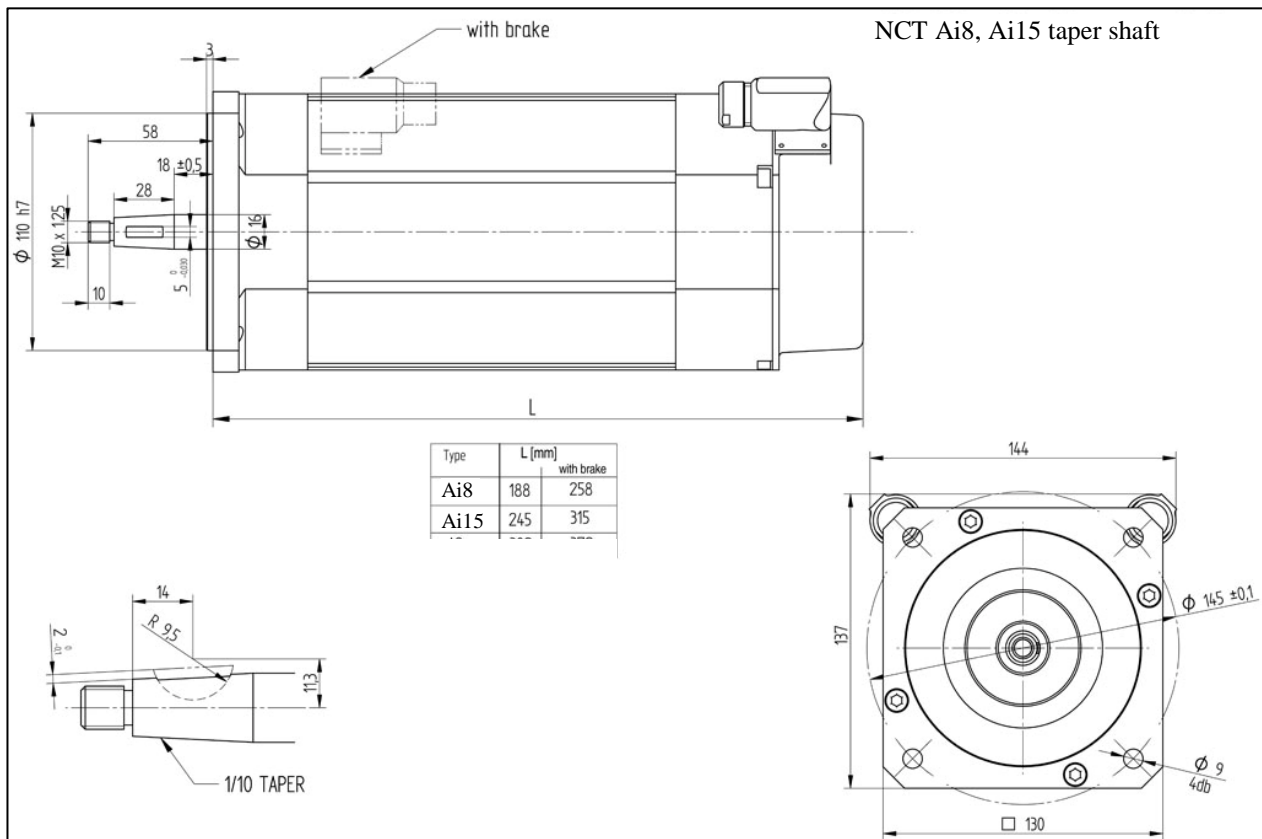

Ai15-54-26-EH/4096

Ai15-54-26-EH/4096-Z AiB15-54-26-EH/4096 AiB15-54-26-EH/4096-Z

Static torque, M_0	17 Nm
Static current, I_0	13 A
Rated output, P_n	2700 W
Rated torque, M_n	9.9 Nm
Rated current, I_n	8.4 A
Rated speed, n_n	2600/min
Maximum torque, M_{max}	75 Nm
Maximum current, I_{max}	68 A
Maximum speed, n_{max}	4000/min
Voltage constant, K_e	82V/(1000/min)
DC bus voltage, U_{DCbusz}	540 V
Moment of inertia (without brake), J	32 kgcm ²
Mass, m	12 kg
Mass with brake, m	15.5 kg
Line resistance, R	0.466 Ω
Protection class	IP55
Insulation class	F
Incremental encoder/resolution	ERN1326/4096
Absolute encoder Single/Multiturn	ECN1325/EQN1337
Brake	Available

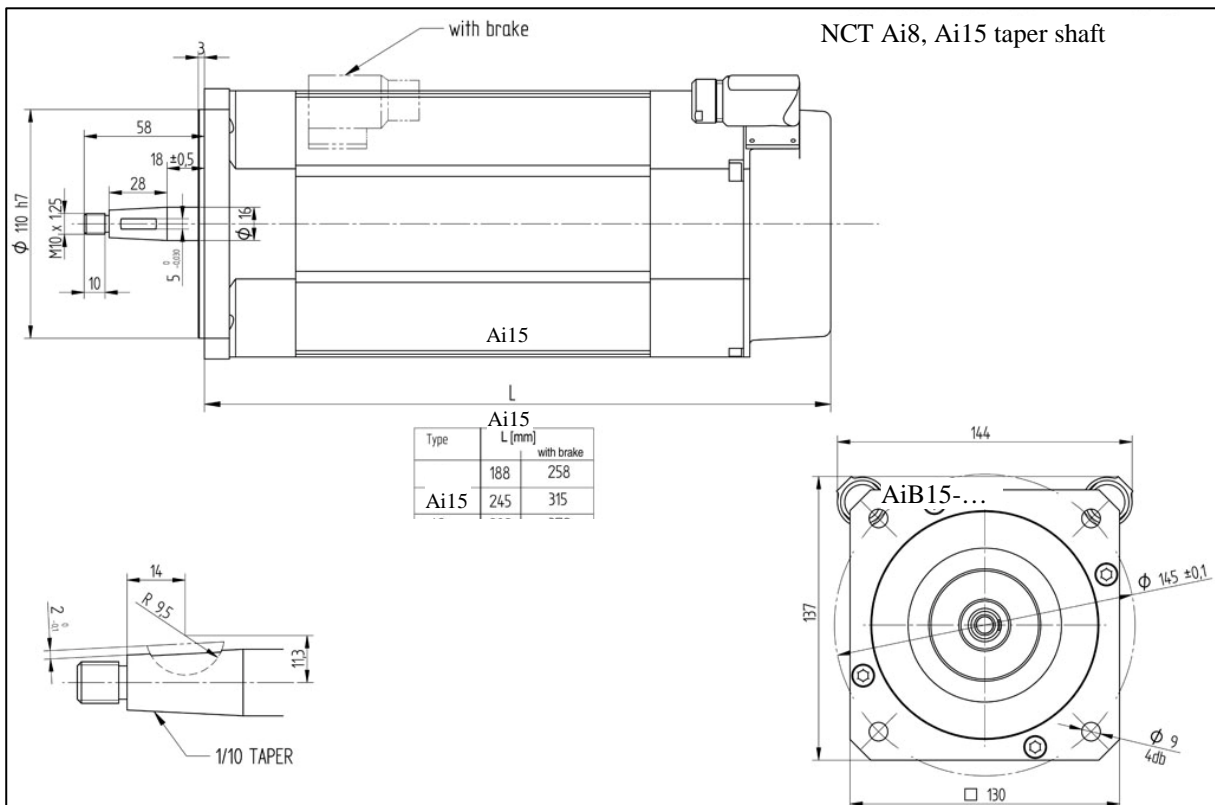
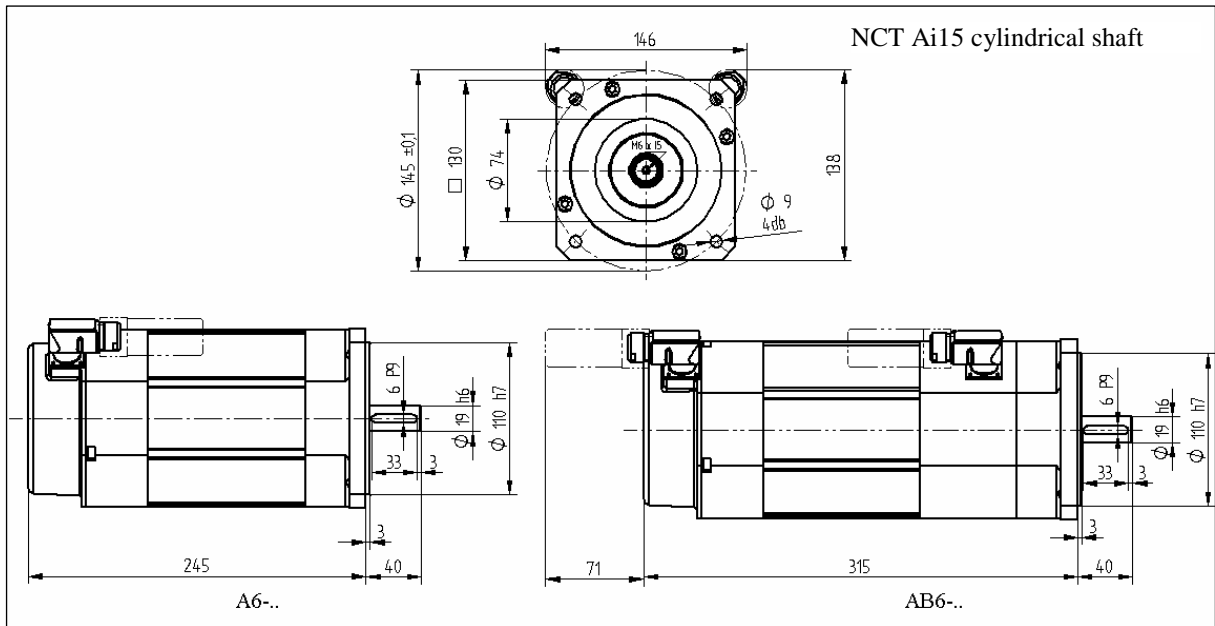

Ai28-54-25-EH/4096

Ai28-54-25-EH/4096-Z Ai28-54-25-EH/4096 AiB28-54-25-EH/4096-Z

Static torque, M_0	29 Nm
Static current, I_0	18.8 A
Rated output, P_n	4130 W
Rated torque, M_n	15.8 Nm
Rated current, I_n	10.6 A
Rated speed, n_n	2500/min
Maximum torque, M_{max}	100 Nm
Maximum current, I_{max}	70 A
Maximum speed, n_{max}	3300/min
Voltage constant, K_e	98V/(1000/min)
DC bus voltage, U_{DCbusz}	540 V
Moment of inertia (without brake), J	64 kgcm ²
Mass, m	18 kg
Mass with brake, m	21 kg
Line resistance, R	0.34 Ω
Protection class	IP55
Insulation class	F
Incremental encoder/resolution	ERN1326/4096
Absolute encoder Single/Multiturn	ECN1325/EQN1337
Brake	Available

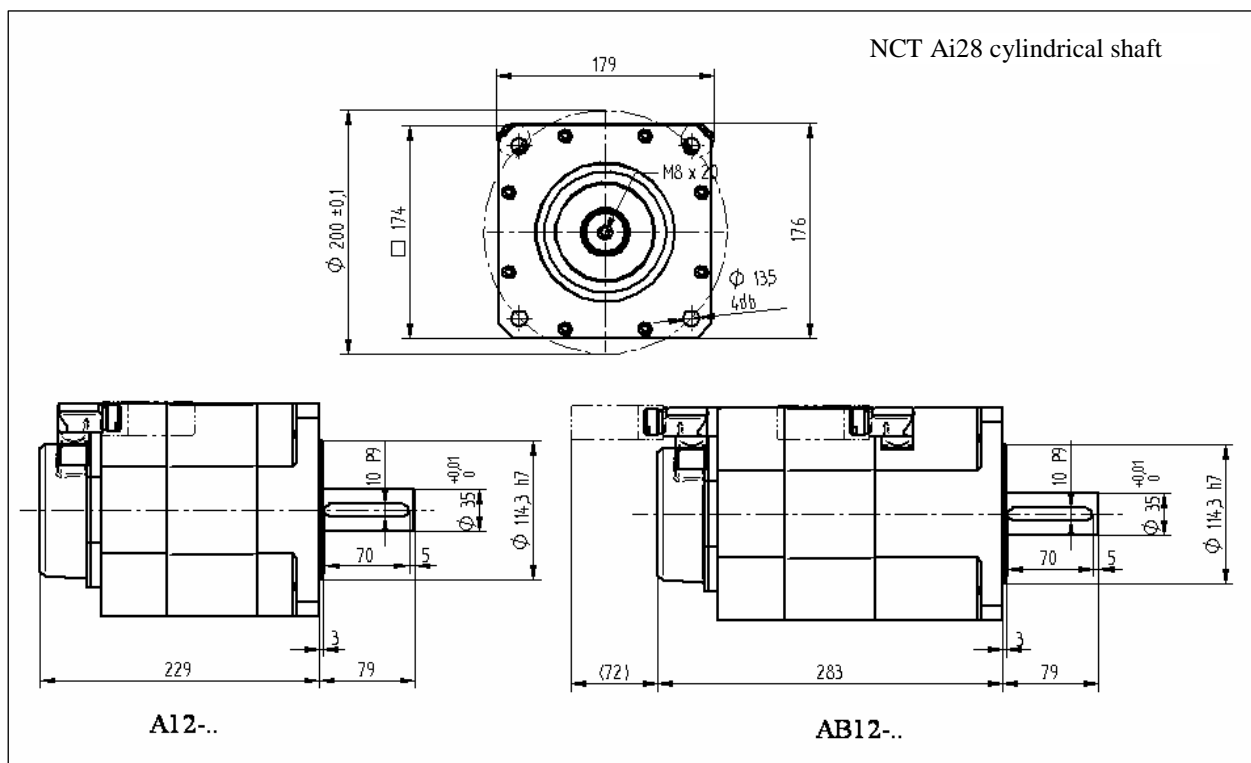

Ai50-54-20-EH/4096

Ai50-54-20-EH/4096-Z AiB50-54-20-EH/4096 AiB50-54-20-EH/4096-Z

Static torque, M_0	51 Nm
Static current, I_0	32.6 A
Rated output, P_n	4980 W
Rated torque, M_n	23.7 Nm
Rated current, I_n	16 A
Rated speed, n_n	2000/min
Maximum torque, M_{max}	200 Nm
Maximum current, I_{max}	150 A
Maximum speed, n_{max}	2500/min
Voltage constant, K_e	98V/(1000/min)
DC bus voltage, U_{DCbusz}	540 V
Moment of inertia, J^*	124 kgcm ²
Mass, m	30 kg
Mass with brake, m	33 kg
Line resistance, R	0.125 Ω
Protection class	IP55
Insulation class	F
Incremental encoder/resolution	ERN1326/4096
Absolute encoder Single/Multiturn	ECN1325/EQN1337
Brake	Available

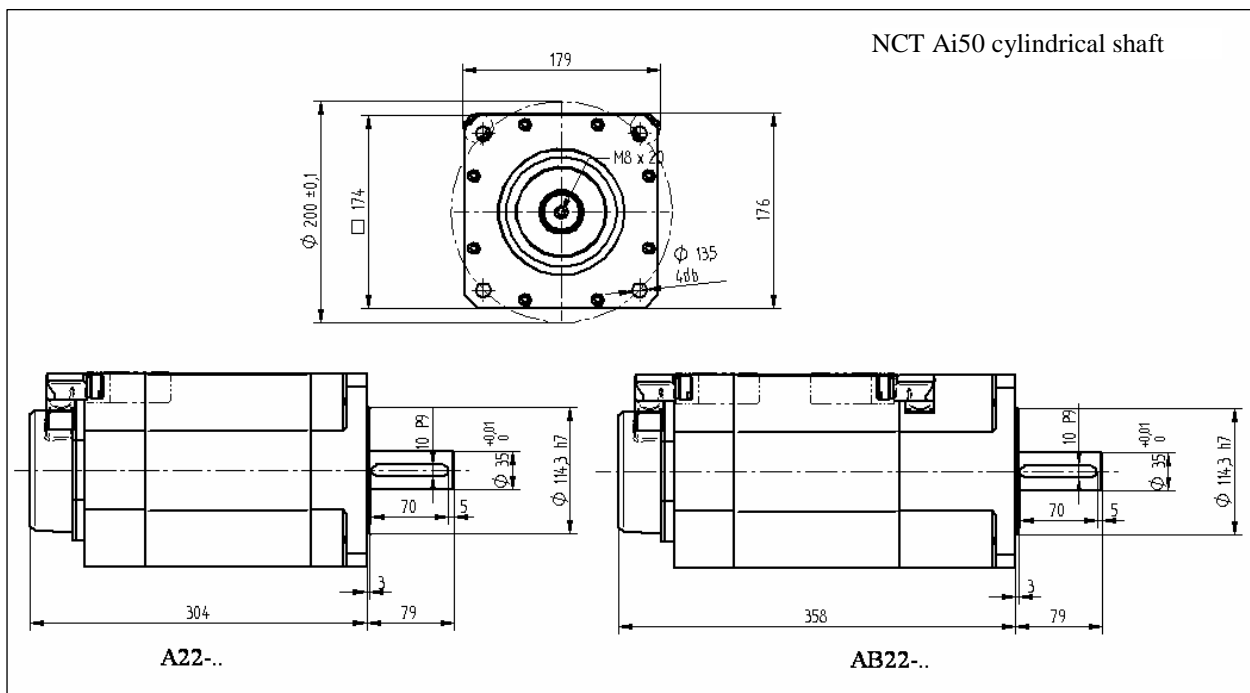

Ai70-54-20-EH/4096

Ai70-54-20-EH/4096-Z AiB70-54-20-EH/4096 AiB70-54-20-EH/4096-Z

Static torque, M_0	70 Nm
Static current, I_0	40 A
Rated output, P_n	5600 W
Rated torque, M_n	27 Nm
Rated current, I_n	16 A
Rated speed, n_n	2000/min
Maximum torque, M_{max}	280 Nm
Maximum current, I_{max}	180 A
Maximum speed, n_{max}	2300/min
Voltage constant, K_e	110V/(1000/min)
DC bus voltage, U_{DCbusz}	540 V
Moment of inertia (without brake), J	147.6 kgcm ²
Mass, m	43 kg
Mass with brake, m	46 kg
Line resistance, R	0.092 Ω
Protection class	IP55
Insulation class	F
Incremental encoder/resolution	ERN1326/4096
Absolute encoder Single/Multiturn	ECN1325/EQN1337
Brake	Available

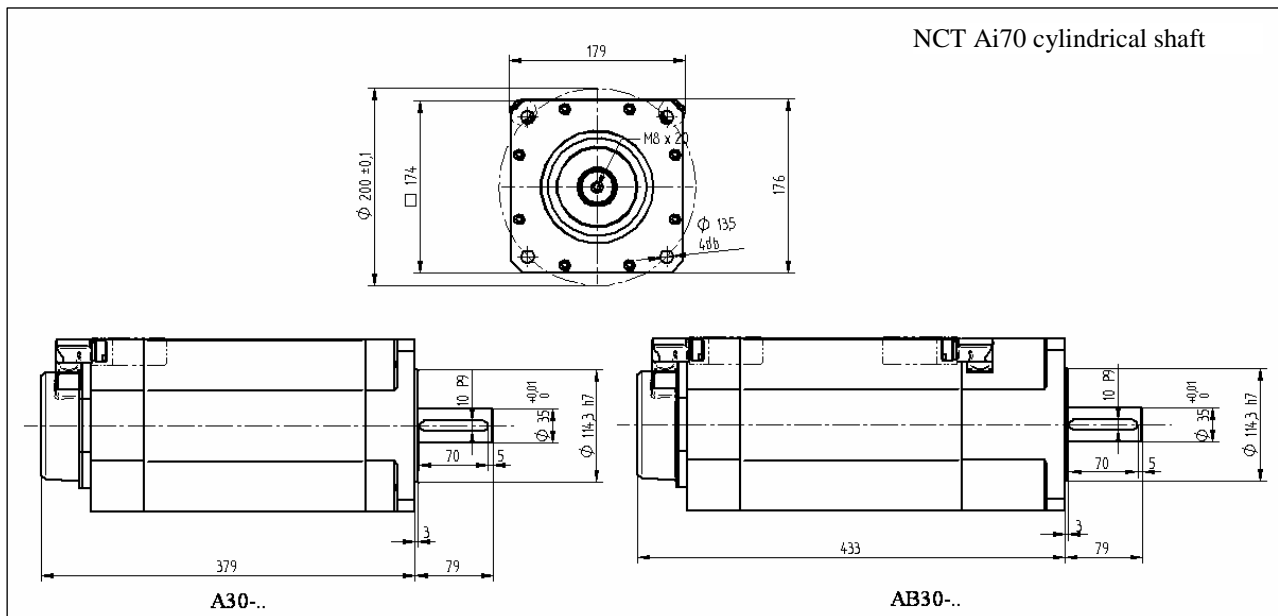

Asynchronous servomotors

NCT asynchronous servomotors have been specifically designed for spindles of machine tools. Thanks to the special configuration, these motors meet high level dynamic requirements of modern machine-tools, they are built for long life, and have a maintenance-free operation. The hollow shaft of AiS spindle motors allows cooling-lubricating medium to be fed to an internally cooled tool (CTS).

NCT motor spindles AMS112 and AMS180 have been specifically designed for lathes. Spindle nose and asynchronous motor are integrated in these compact motor spindles. Their dynamic rigidity and low vibration tendency make a further leap in machining quality.

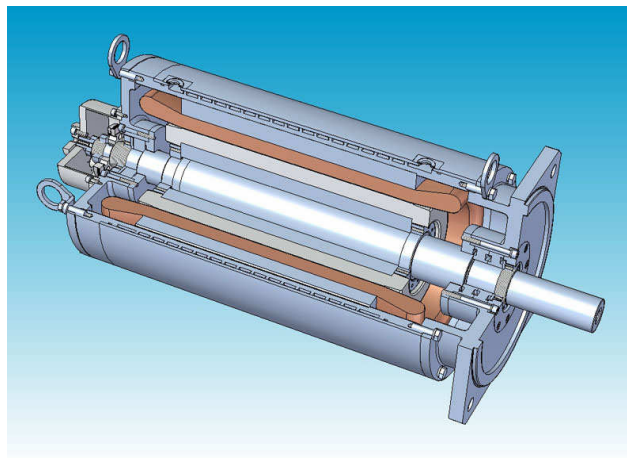

NCT spindle motor AiS

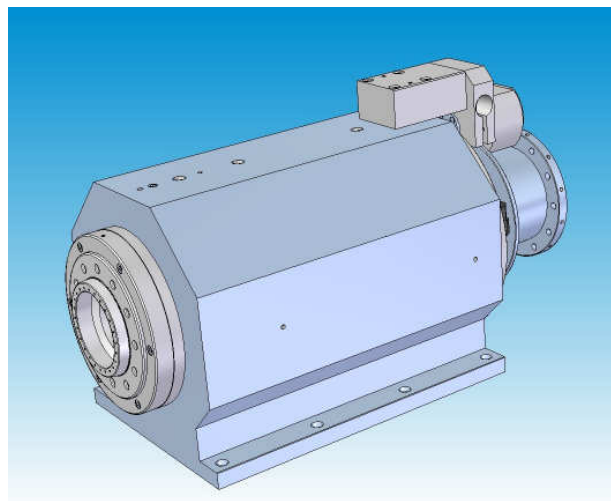

NCT motor spindle AMS

Definitions of the motor technical specifications

M_0	continuous torque at zero speed
I_0	phase current at M_0
P_n	rated output
M_n	rated torque
I_n	phase current at M_n
U_n	line voltage at M_n
n_n	rated speed
f_n	rated frequency
I_μ	magnetizing current
$\cos\varphi_n$	power factor
η_n	efficiency
n_{mgy}	limit of the field weakening , so far this speed the rated output is static
M_{max}	maximum torque
n_{max}	maximum speed

Summing table

Motor model	Note	Rated output P_n	Rated current I_n	Rated torque M_n	Rated/max. speed n_n/n_{max}
AiS100LW15H	Flange	10.5 kW	24 A	67 Nm	1500/10000/min
AiS100LW20H	Flange	15 kW	32 A	72 Nm	2000/15000/min
AiS132LW15H	Flange	22 kW	55 A	140 Nm	1500/10000/min
AMS112MW20H	Motor spindle	9.5 kW	27 A	45 Nm	2000/6000/min
AMS180SW20H	Motor spindle	22 kW	53 A	105 Nm	2000/6000/min
AMS180MW20H	Motor spindle	35 kW	91 A	167 Nm	2000/6000/min
AMS180LW20H (Y)	Motor spindle	18.2 kW	47.5 A	173.8 Nm	1000/6000/min
AMS180LW20H (D)	Motor spindle	23.4 kW	47.4 A	89.4 Nm	2500/6000/min
MDFKATS071-22	Flange	2.2 kW	6.0 A	6.3 Nm	3410/8000/min
MDFKATS080-22	Flange	3.9 kW	9.1 A	10.8 Nm	3455/8000/min
DA 100B 54 A 17-5	Foot mounted	11.0 kW	27.8 A	60.0 Nm	1750/8000/min
DA F 100B 54 A 17-5	Flange				
DA FF 100B 54 A 17-5	Feet+Flange				
DA 132K 23 A 10-5	Foot mounted	15.0 kW	38.0 A	143 Nm	1000/5000/min
DA F 132K 23 A 10-5	Flange				
DA FF 132K 23 A 10-5	Feet+Flange				
DA 132L 23 A 10-5	Foot mounted	20.0 kW	48.0 A	191 Nm	1000/5000/min
DA F 132L 23 A 10-5	Flange				
DA FF 132L 23 A 10-5	Talpas-peremes				

AiS100LW15H

Rated output, P_n	10.5 kW
Rated torque, M_n	67 Nm
Rated current, I_n	24 A
Magnetizing current, I_μ	12 A
Rated speed, n_n	1500 rpm
Field weakening limit, n_{mgy}	7200 rpm
Max. speed, n_{max}	10000 rpm
Rated frequency f_n	51.5 Hz
Power factor, $\cos\varphi_n$	0.85
Efficiency, η_n	0.90
Rated voltage, U_n	330 V
Moment of inertia, J	245 kgcm ²
Weight, m	85 kg
Degree of protection	IP54
Class of insulation	F
Cooling method	Liquid cooling
Type of the encoder	GEL 244
Resolution/type of the encoder	256/TTL

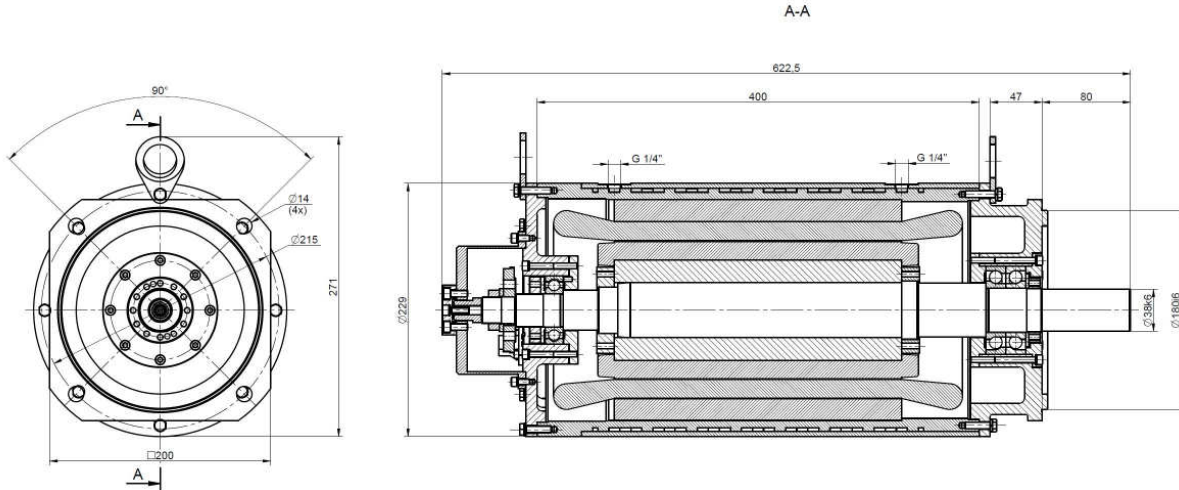

AiS100LW20H

Rated output, P_n	15 kW
Rated torque, M_n	72 Nm
Rated current, I_n	32 A
Magnetizing current, I_μ	12 A
Rated speed, n_n	2000 rpm
Field weakening limit, n_{mgy}	8500 rpm
Max. speed, n_{max}	15000 rpm
Rated frequency f_n	68.5 Hz
Power factor, $\cos\varphi_n$	0.89
Efficiency, η_n	0.91
Rated voltage, U_n	330 V
Moment of inertia, J	245 kgcm ²
Weight, m	85 kg
Degree of protection	IP54
Class of insulation	F
Cooling method	Liquid cooling
Type of the encoder	GEL 244
Resolution/type of the encoder	256/TTL

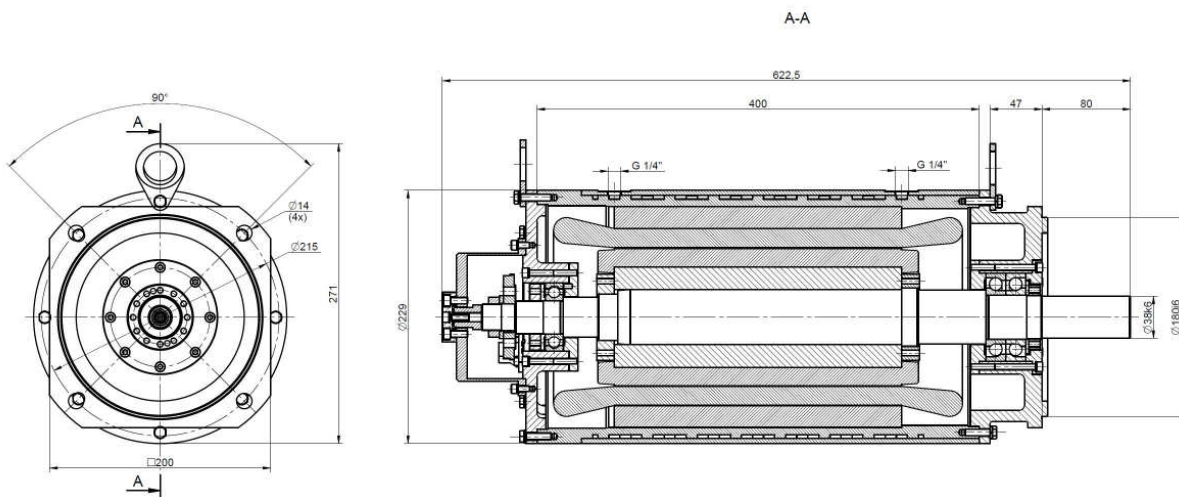

AiS132LW15H

Rated output, P_n	22.0 kW
Rated torque, M_n	140 Nm
Rated current, I_n	55 A
Magnetizing current, I_μ	23 A
Rated speed, n_n	1500 rpm
Field weakening limit, n_{mgy}	6500 rpm
Max. speed, n_{max}	10000 rpm
Rated frequency f_n	51.1 Hz
Power factor, $\cos\varphi_n$	0.84
Efficiency, η_n	0.92
Rated voltage, U_n	300 V
Moment of inertia, J	1100 kgcm ²
Weight, m	160 kg
Degree of protection	IP54
Class of insulation	F
Cooling method	Liquid cooling
Type of the encoder	GEL 244
Resolution/type of the encoder	256/TTL

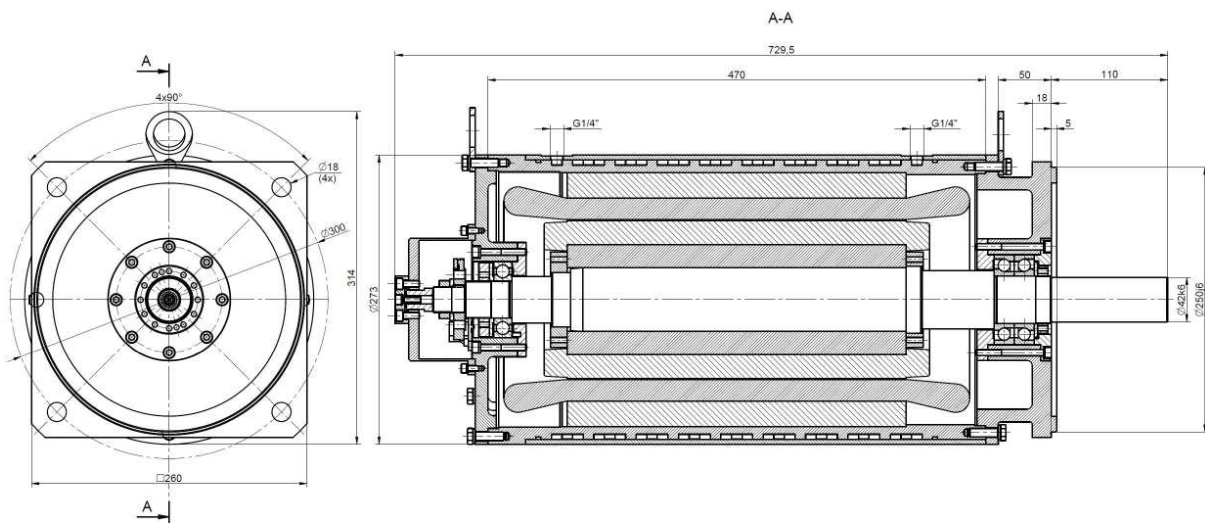

AMS112MW20H

Rated output, P_n	9,5 kW
Rated torque, M_n	45 Nm
Rated current, I_n	27 A
Magnetizing current, I_μ	18 A
Rated speed, n_n	2000 rpm
Field weakening limit, n_{mgy}	4500 rpm
Max. speed, n_{max}	6000 rpm
Rated frequency f_n	70.1 Hz
Power factor, $\cos\phi_n$	0.77
Efficiency, η_n	0.85
Rated voltage, U_n	310 V
Moment of inertia, J	210 kgcm ²
Weight, m	44 kg
Degree of protection	IP54
Class of insulation	F
Cooling method	Liquid cooling
Type of the encoder (magnetic)	ERM200/900RA A05
Type of the sensor	AK ERM 280

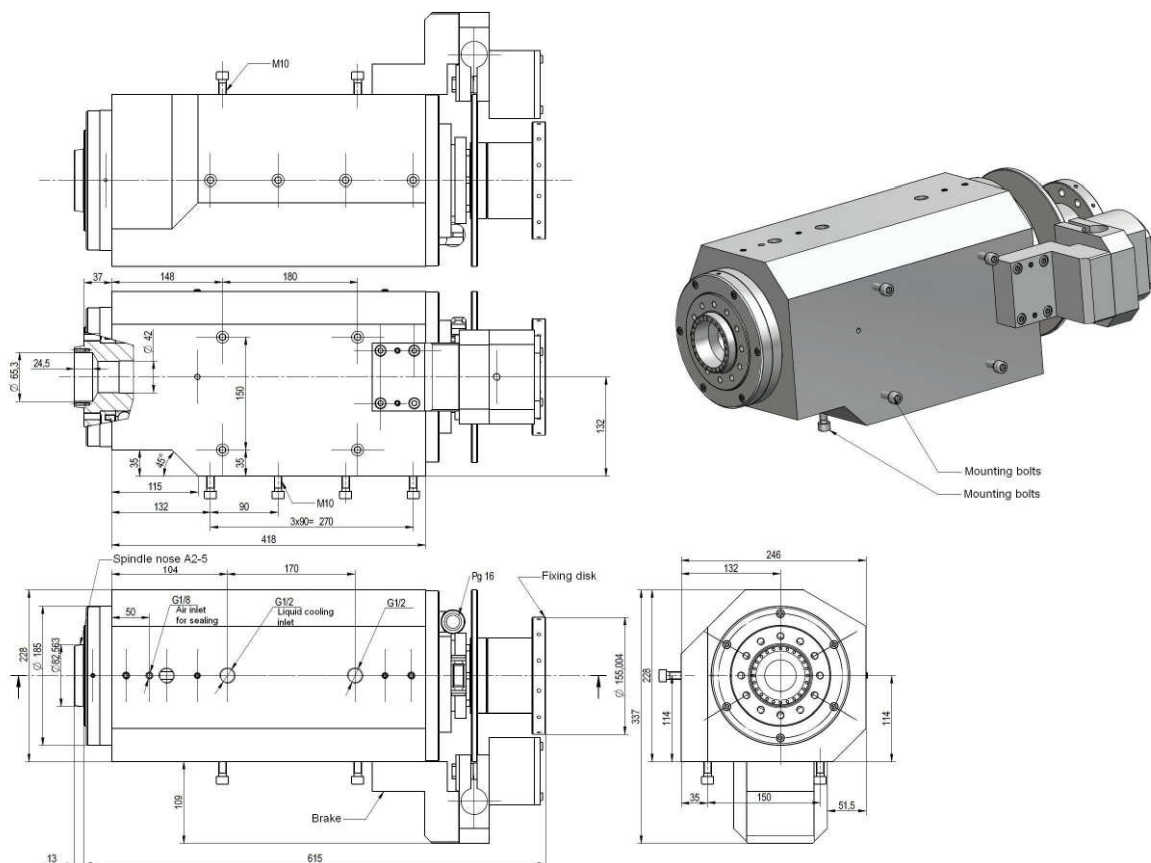

AMS180SW20H

Rated output, P_n	22 kW
Rated torque, M_n	105 Nm
Rated current, I_n	53 A
Magnetizing current, I_{μ}	21 A
Rated speed, n_n	2000 rpm
Field weakening limit, n_{mgy}	5000 rpm
Max. speed, n_{max}	6000 rpm
Rated frequency f_n	68.1 Hz
Power factor, $\cos\phi_n$	0.87
Efficiency, η_n	0.92
Rated voltage, U_n	300 V
Moment of inertia, J	1540 kgcm ²
Weight, m	122 kg
Degree of protection	IP54
Class of insulation	F
Cooling method	Liquid cooling
Type of the encoder (magnetic)	ERM200/1200RA A03
Type of the sensor	AK ERM 280

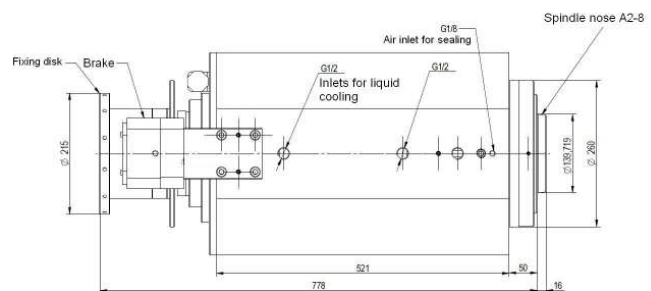
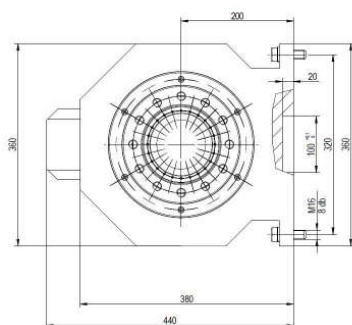
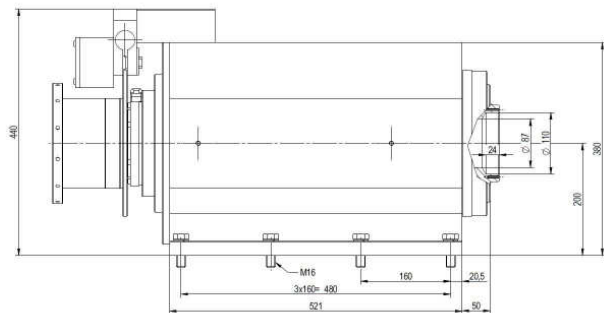
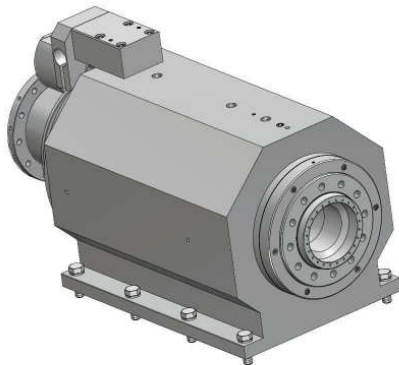

AMS180LW20H

Rated output, P_n	18.2 kW	23.4 kW
Rated torque, M_n	173.8 Nm	89.4 Nm
Rated current, I_n	47.5 A	47.4 A
Magnetizing current, I_μ	25 A	17 A
Rated speed, n_n	1000 rpmc	2500 rpm
Field weakening limit, n_{mgy}	2800 rpm	6000 rpm
Max. speed, n_{max}	6000 rpm	6000 rpm
Rated frequency f_n	34.8 Hz	84.5 Hz
Power factor, $\cos\varphi_n$	0.80	0.86
Efficiency, η_n	0.87	0.92
Rated voltage, U_n	320 V Y	360 V D
Moment of inertia, J	1540 kgcm ²	1540 kgcm ²
Weight, m	122 kg	122 kg
Degree of protection	IP54	IP54
Class of insulation	F	F
Cooling method	Liquid cooling	Liquid cooling
Type of the encoder (magnetic)	ERM200/1200RA A03	ERM200/1200RA A03
Type of the sensor	AK ERM 280	AK ERM 280

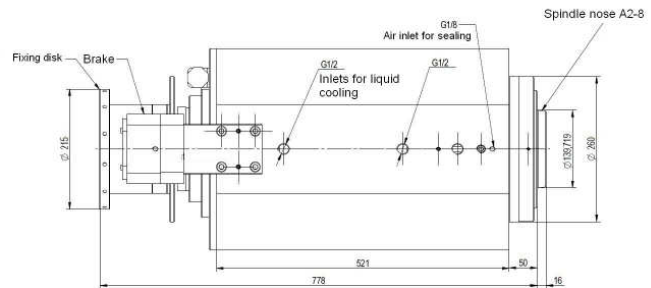
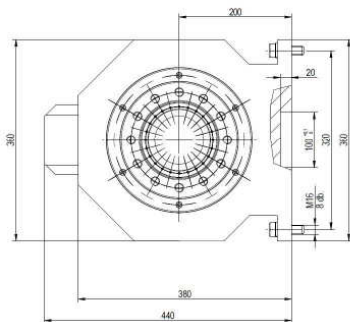
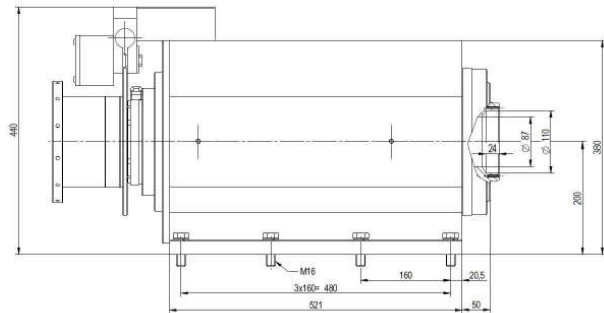
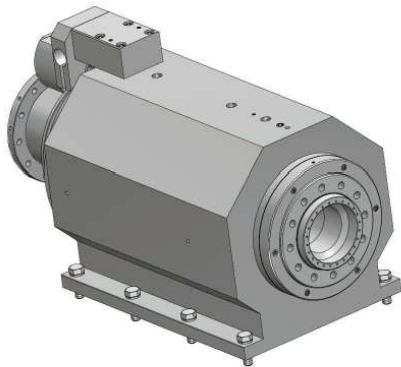

MDFKARS080-22

Static torque, M_0	13.5 Nm
Static current, I_0	10.5 A
Rated output, P_n	3.9 kW
Rated torque, M_n	13.5 Nm
Rated current, I_n	9.1 A
Rated speed, n_n	3455 /min
Maximum torque, M_{max}	60 Nm
Maximum speed, n_{max}	8000 /min
Rated frequency, f_n	120 Hz
Power factor, $\cos\phi_n$	0.80
Rated voltage, U_n	390 V
Moment of inertia, J	19.2 Kgcm ²
Mass, m	17 kg
Protection class	IP54
Insulation class	F
Type of the encoder	OIH48-1024P6-L6-5V
Resolution of the encoder	1024

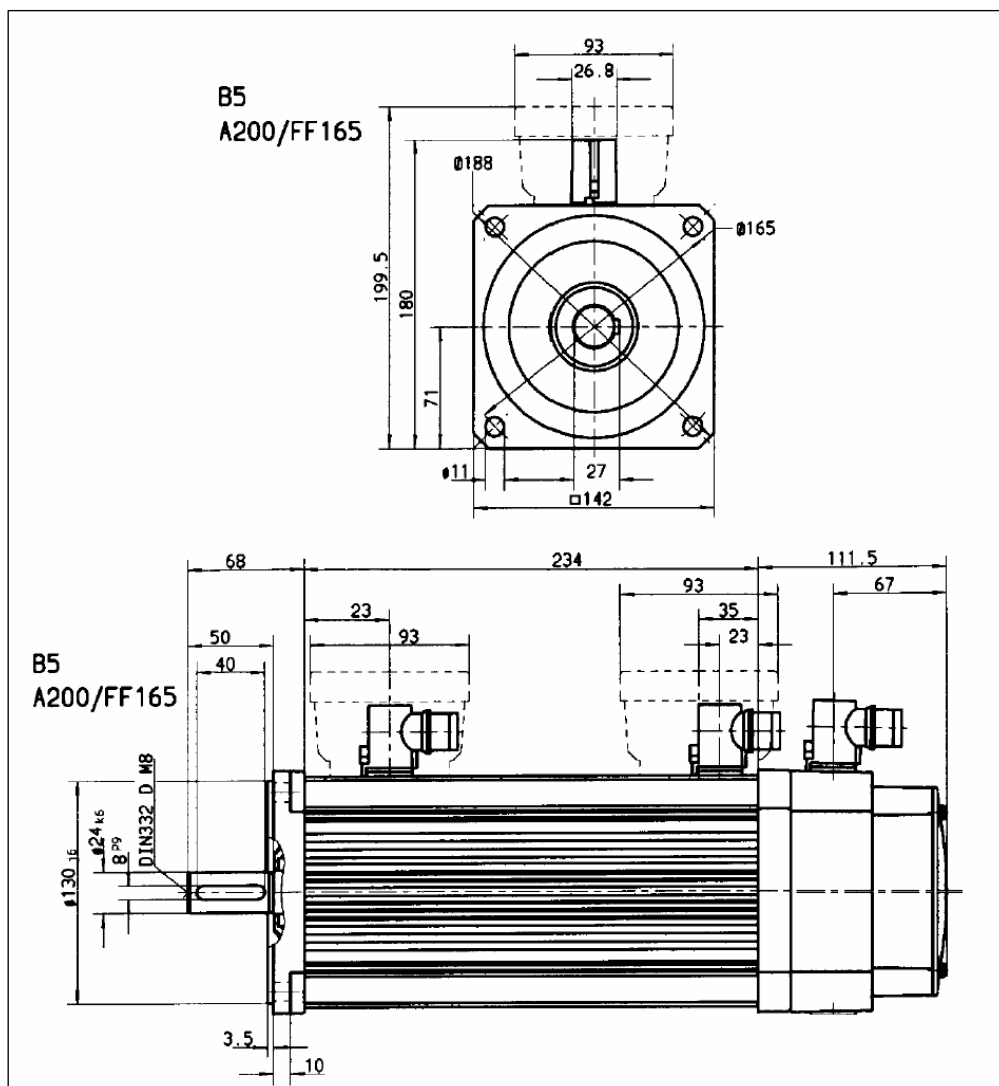

DA 100B 54 A 17-5

DA F 100B 54 A 17-5 DA FF 100B 54 A 17-5

Rated output, P_n	11.0 kW
Rated torque, M_n	60 Nm
Rated current, I_n	27.8 A
Magnetizing current, I_μ	15.2 A
Rated speed, n_n	1750 /min
Limit of the field weakening , n_{mgy}	3500 /min
Maximum speed, n_{max}	8000 /min
Rated frequency, f_n	60.3 Hz
Power factor, $\cos\varphi_n$	0.78
Efficiency, η_n	0.878
Rated voltage, U_n	335 V
Moment of inertia, J	340 Kgcm ²
Mass, m	75 kg
Protection class	IP54
Insulation class	F
Type of the encoder	ERN420
Resolution of the encoder	1024

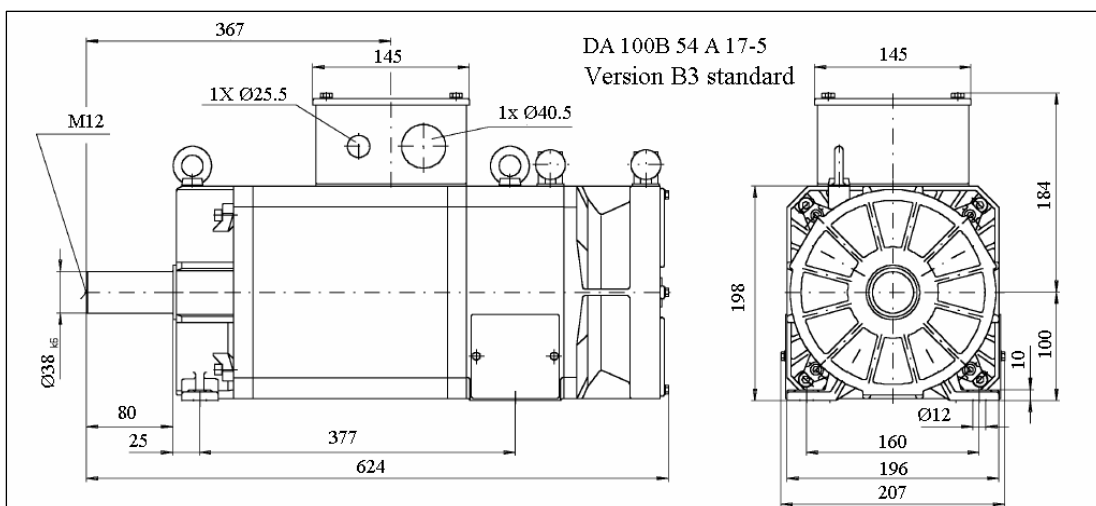
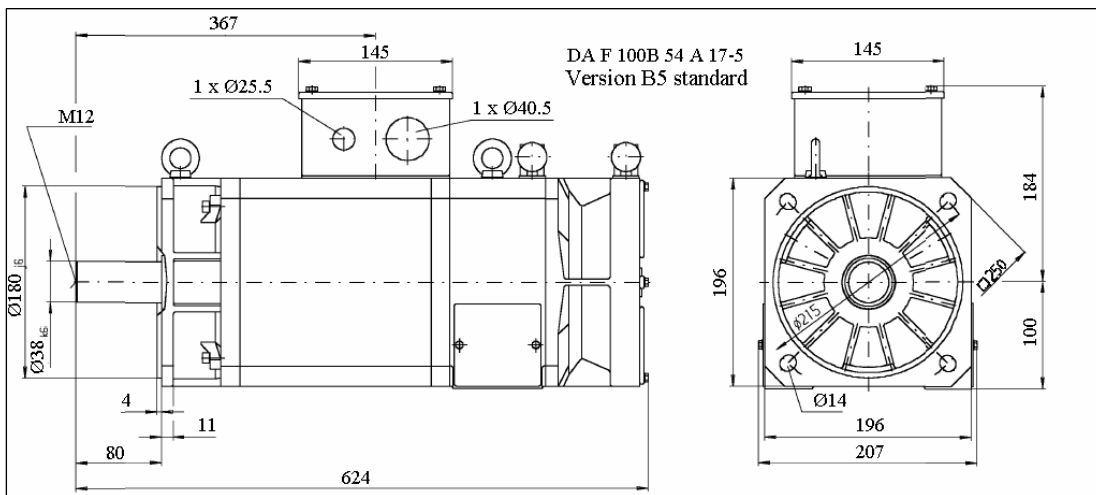

DA 132K 23 A 10-5
DA F 132K 23 A 10-5 DA FF 132K 23 A 10-5

Rated output, P_n	15 kW
Rated torque, M_n	143 Nm
Rated current, I_n	38.0 A
Magnetizing current, I_μ	18.6 A
Rated speed, n_n	1000 /min
Limit of the filed reduction, n_{mgy}	2600 /min
Maximum speed, n_{max}	5000 /min
Rated frequency, f_n	35.0 Hz
Power factor, $\cos\varphi_n$	0.82
Efficiency, η_n	0.835
Rated voltage, U_n	335 V
Moment of inertia, J	740 Kgcm ²
Mass, m	128 kg
Protection class	IP23
Insulation class	F
Type of the encoder	ERN420
Resolution of the encoder	1024

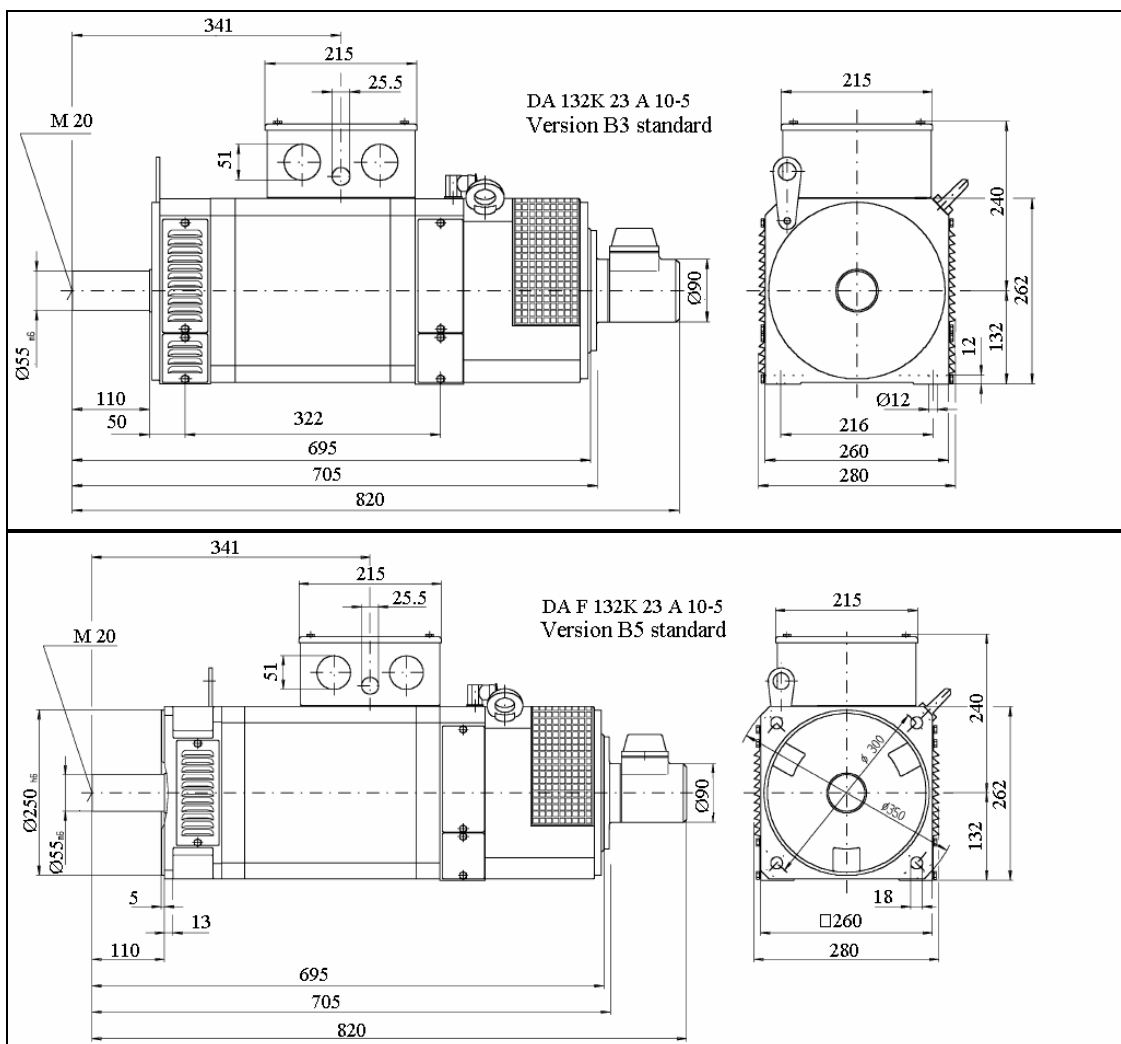

DA 132L 23 A 10-5
DA F 132L 23 A 10-5 DA FF 132L 23 A 10-5

Rated output, P_n	20 kW
Rated torque, M_n	191 Nm
Rated current, I_n	42.0 A
Magnetizing current, I_μ	23.9 A
Rated speed, n_n	1000 /min
Limit of the field weakening , n_{mgy}	2200 /min
Maximum speed, n_{max}	5000 /min
Rated frequency, f_n	34.8 Hz
Power factor, $\cos\varphi_n$	0.82
Efficiency, η_n	0.862
Rated voltage, U_n	345 V
Moment of inertia, J	1050 Kgcm ²
Mass, m	158 kg
Protection class	IP23
Insulation class	F
Type of the encoder	ERN420
Resolution of the encoder	1024

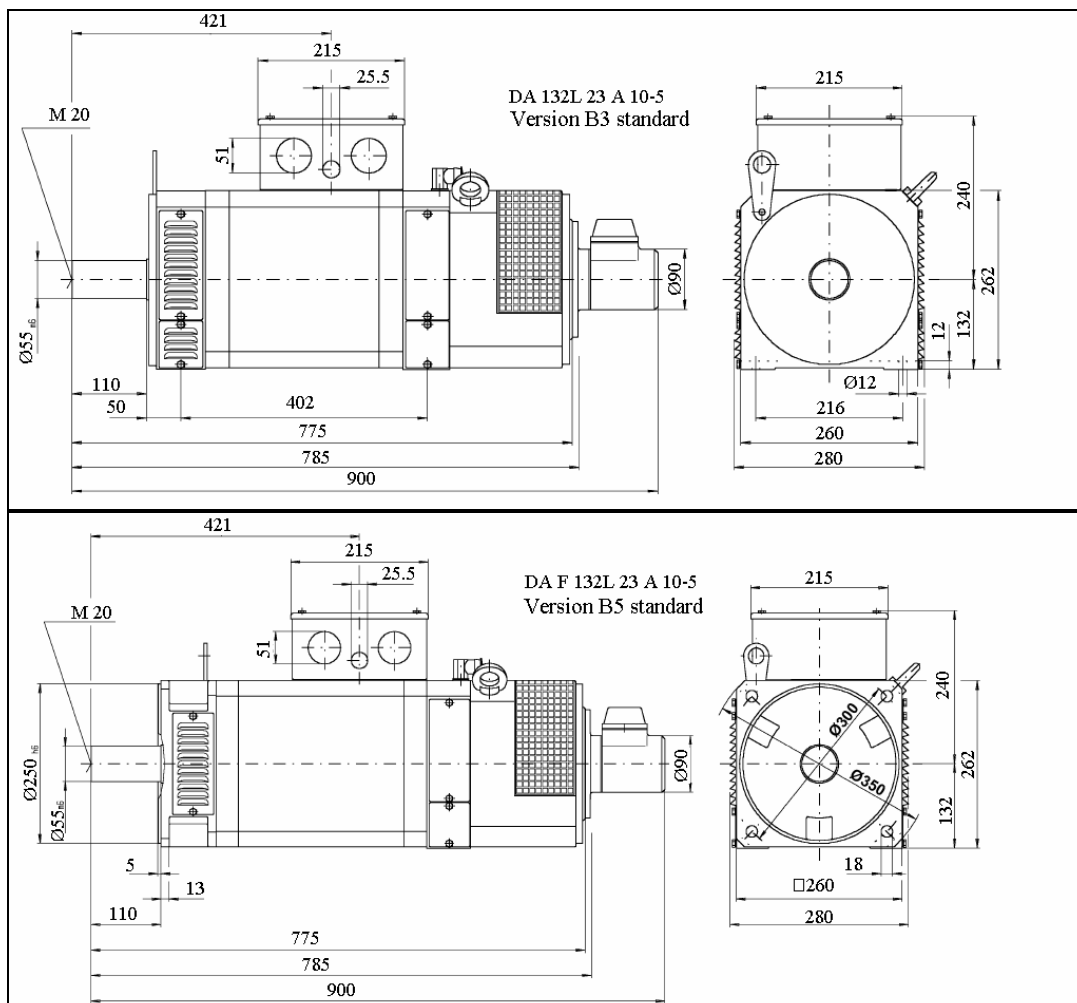

Encoders

The encoder is mounted on the shaft of the motor. The encoder provides informations for the current-controller of the synchronous servo drives about the position of the pole-core and the speed-controller of asynchronous servo drives about the actual speed.

Incremental encoders for synchronous servomotors A1 – A38, AB3 -.AB38 and Ai2.5 –Ai-70, AiB2.5 – AiB70.

Manufacturer: HEIDENHAIN

Type: ERN1326

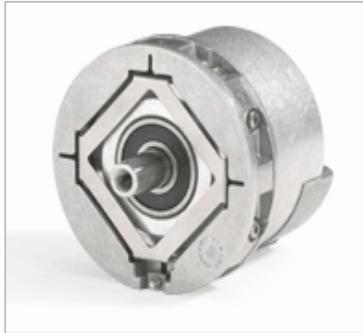

The encoder is not water-proof, so the cover of the motor protects it from water.

The encoder provides the following signals:

Incremental signals with complements (A, \bar{A} , B, \bar{B})

Reference signal with complement (C, \bar{C})

Commutation signals with complements (I, II, III, \bar{I} , \bar{II} , \bar{III})

Required power-supply voltage: 5V

The output level: TTL

The resolution of the encoder: 4096

Suitable cable: (HEIDENHAIN) shielded cable

PUR[4(2x0.14mm²)+ 4(2x0.14mm²)+ (4x0.5mm²)]

The maximum length of cable: 100m

Absolute encoders for synchronous servomotors A1 – A38, AB3 -.AB38 and Ai2.5 –Ai-70, AiB2.5 – AiB70.

Manufacturer: HEIDENHAIN

Type: ECN1325 (singleturn) and EQN1337 (multiturn)



The encoders are not water-proof, so the cover of the motor protects it from water.

The encoders provide absolute position information immediately after switch on. This makes it immediately possible to derive the exact position of the rotor and use it for electronic commutation.

The encoder provides the following signals:

Synchronous serial EnDat 2.2 interface (CLOCK+, CLOCK-, DATA+, DATA-)

Required power-supply voltage: 5V

Position values per revolution: 33554432 (25 bits)

Revolutions: 4096 (12 bits) for EQN1327 only

Suitable cable: Heidenhain AWM STYLE 20963 80 C 30V E63216 or equivalent

The maximum length of cable: 100m (at 8 MHz clock frequency)

Encoder for DA.. type asynchronous servomotors

Manufacturer: HEIDENHAIN

Type: ERN420



The encoder provides the following signals:

Incremental signals with complements (A, \bar{A}, B, \bar{B})

Reference signal with complement (C, \bar{C})

Required power-supply voltage: 5V

The output level: TTL

The resolution of the encoder: 1024

Suitable cable: (HEIDENHAIN) shielded cable

PUR[4(2x0.14mm²) + 4(2x0.14mm²) + (4x0.5mm²)]

The maximum length of cable: 100m

Encoder for MD.. type asynchronous servomotors

Manufacturer: TAMAGAWA SEIKI

Type: OIH48-1024P6-L6-5V



The encoder is not water-proof, so the cover of the motor protects it from water.

The encoder provides the following signals:

Incremental signals with complements (A, \bar{A}, B, \bar{B})

Reference signal with complement (C, \bar{C})

Commutation signals with complements ($I, II, III, \bar{I}, \bar{II}, \bar{III}$)

Required power-supply voltage: 5V

The output level: TTL

The resolution of the encoder: 1024

Suitable cable: shielded cable

PUR[5(2x0.14mm²) + (2x0.5mm²)]

The maximum length of cable: 200m

Encoder connector

Manufacturer: INTERCONTEC

Type: AEWC052MR04

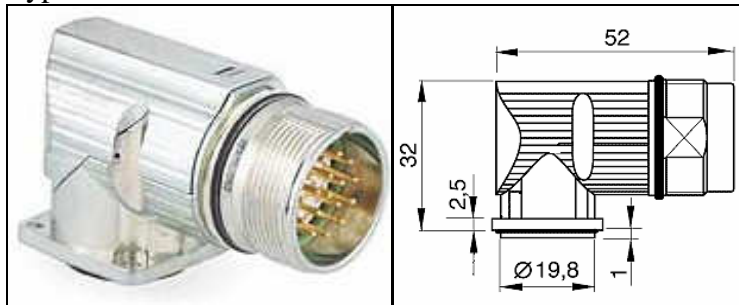

Reverse type: ASTA021FS13

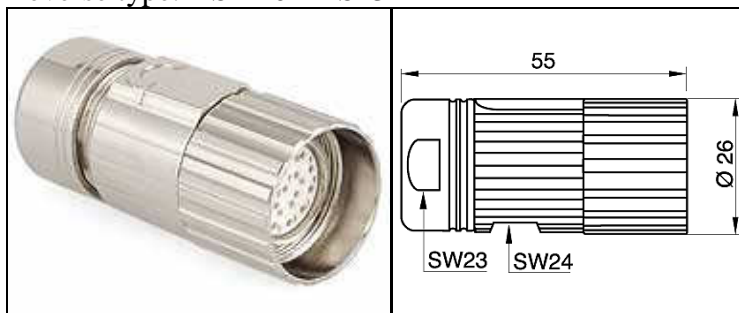

Connector pin layout for incremental encoder ERN1326
(shown from the connecting end):

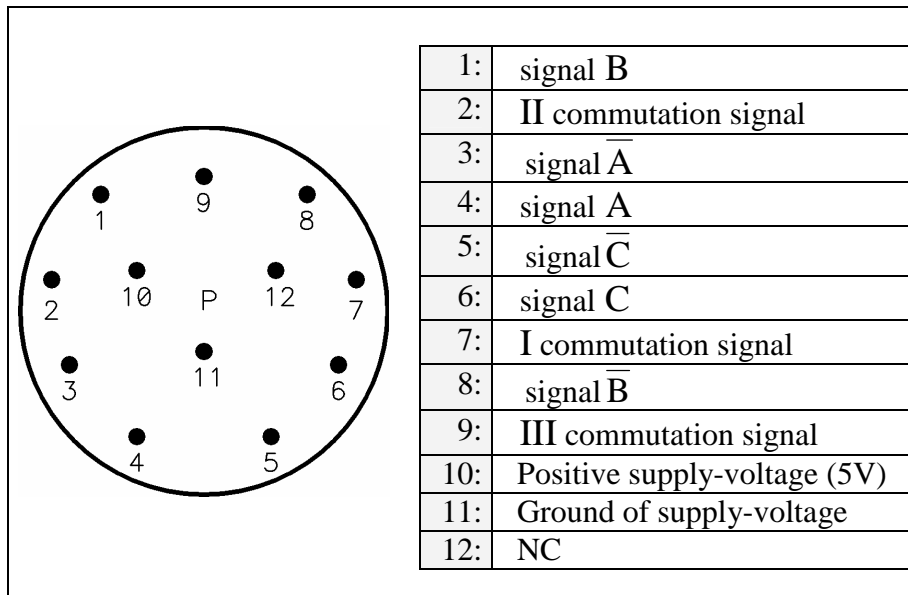

The complements of commutation signals are not available in the connector.

Connector pin layout for absolute encoders ECN1325 and EQN1337
(shown from the connecting end):

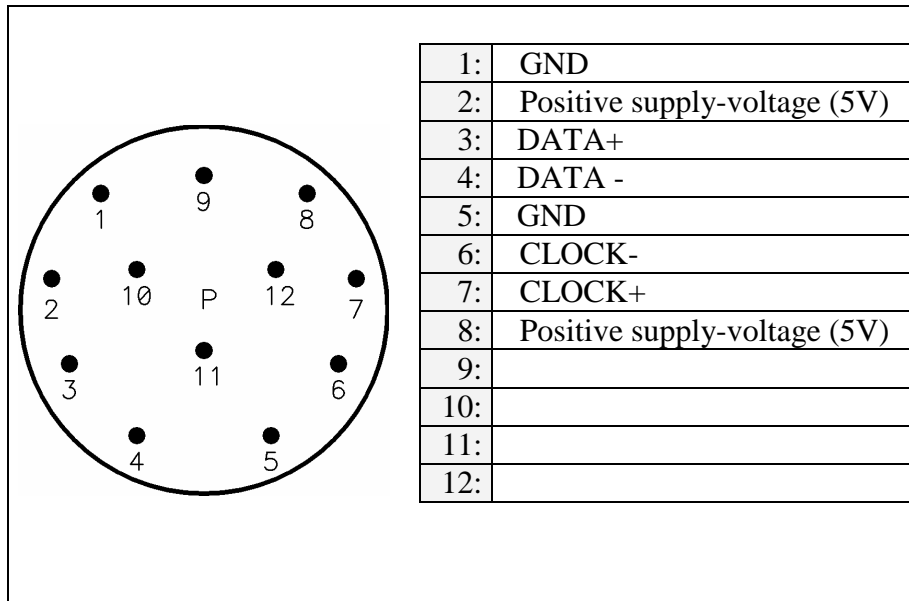

Power connector

Power connector for synchronous servomotors A1 - A38 and Ai2.5 – Ai 70

Manufacturer: INTERCONTEC

Type: BEWC089MR13

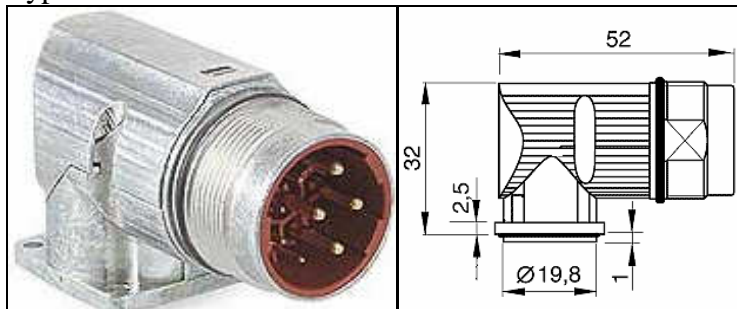

Reverse type: BSTA078FR05

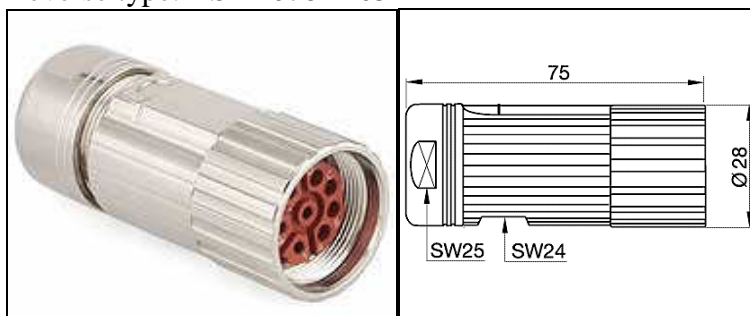

Power connector pin layout (shown from the connecting end):

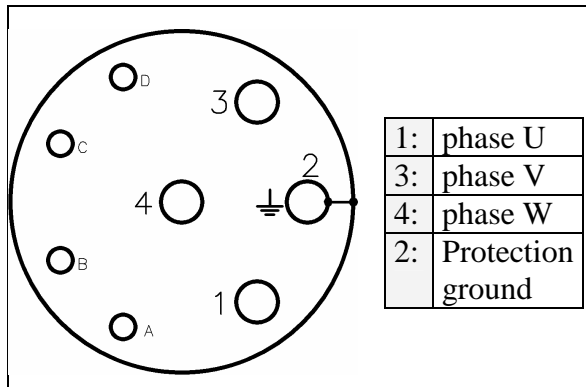

Power connector for MD.. type asynchronous servomotors

Manufacturer: HYPERTAC

Type: GRÖSSE 1 EINBAUDOSE ABGEWINKELT

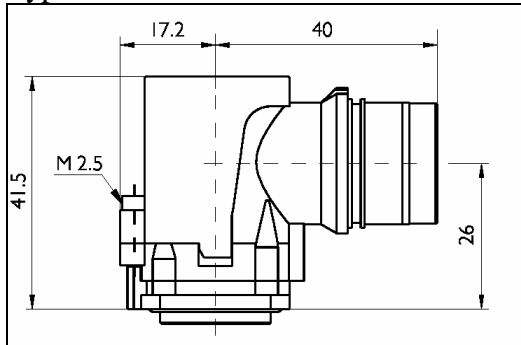

Reverse type: GRÖSSE 1 STECKER SYSTEM 2000

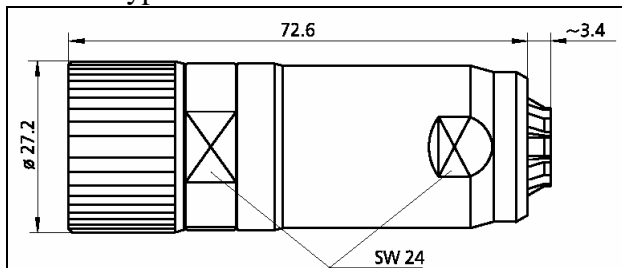

Connector pin layout (shown from the connecting end):

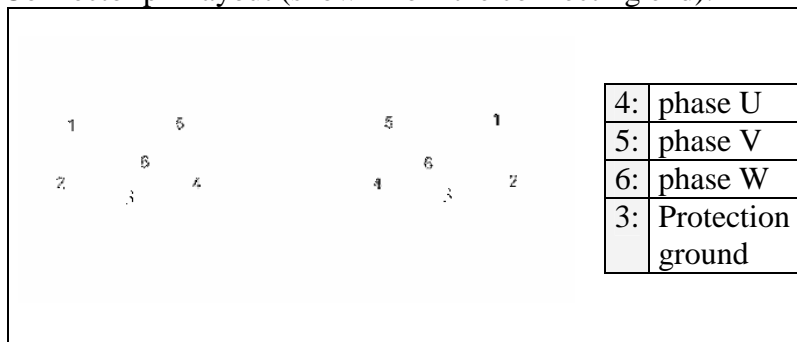

Terminal board for DA.. type asynchronous servomotors

These motors have terminal board located in the terminal box (no special power connector).

Built in holding brake

Fékegység az AB1, AB2, és AiB2.5, AiB5 típusú motorokhoz.

Gyártó: Kendrion

Típus: HIGH TORQUE 86 61105K00

A Kendrion HIGH TORQUE fékegység az egyenfeszültség rákapcsolásakor old ki. A fékben a fékezéshez szükséges súrlódási erőt állandó mágnessel állítják elő. A fékezőerőt úgy lehet megszüntetni, hogy az állandó mágnes mezejét egy elektromágnessel hatástalanítjuk.

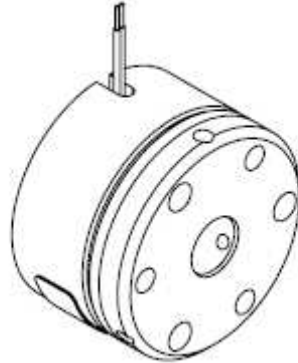

Névleges nyomaték: 5 Nm

Működtető feszültség: 24 V

A működtető tekercs teljesítmény felvétele: 12W

Brake for motors AB3, AB6, AB9.

Manufacturer: Lenze

Model: BFK 457-08



These brakes are so-called spring-operated brakes, it means that in no voltage case they hold and if voltage is switched on they release. This provide security, because in emergency, when the supply voltage is switched off, the motor retards mechanically.

Reted torque: 8Nm

Supply voltage: 24V

The power requirement of the activating coil: 25W

Brake for motors AB12, AB22, AB30, AB38 and AiB28, AiB50, AiB70.

Manufacturer: Kendrion

Model: PM LINE 8662111H00

The Kendrion PM LINE is comprised of DC operated permanentmagnet single-surface brakes characterised by the fact that the braking effect is produced by a permanentmagnetic field (electromagnetically released system).

This means that the required braking force is generated when voltage is removed. In order to neutralise the braking effect, the permanentmagnetic field is counteracted by an opposing electromagnetic field.



Rated torque: 40 Nm

Supply voltage: 24 V

The power requirement of the activating coil: 24W

The connector of the activating voltage of the brakes for AB and AiB motors

Manufacturer: INTERCONTEC

Type: BEWC089

Connector pin layout (shown from the connecting end):

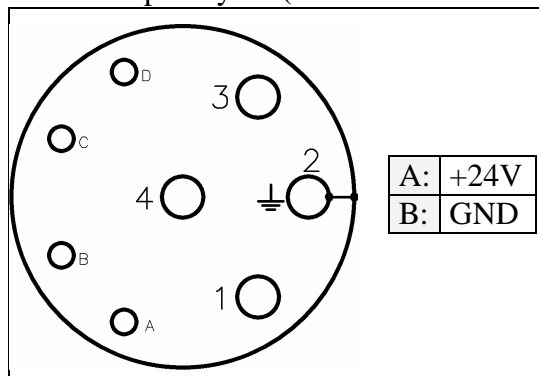

Reverse type: BSTA078

Cooling of the air cooled motors

Synchronous servo motors A, AB, Ai and AiB do not require external fan (natural cooling).

DA100.. asynchronous servo motors:

These motors are cooled with fan driven by a three-phase asynchronous motor.

The fan motor has a six pin type connector.

Connector pin layout (shown from the connecting end):

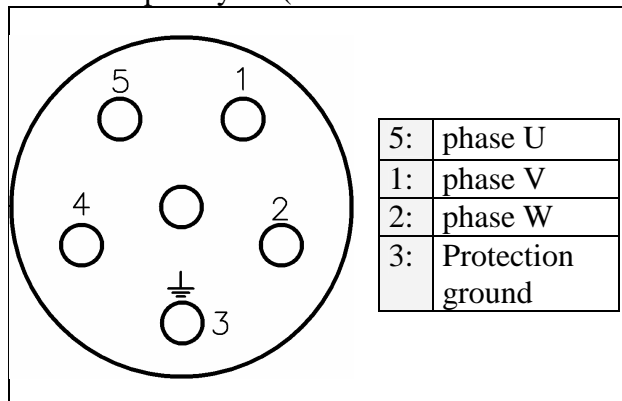

Rated voltage of the motor: 400-460V 50/60Hz

Rated current of the motor: 0.13A

Check rotation direction of the fan, after connecting the motor.

DA132.. asynchronous servo motor:

These motors are cooled with a fan driven by a three-phase asynchronous motor.

The fan motor is connected via terminal board located in the terminak box.

Motor (star-connected):

Rated voltage: 345-460V 50/60Hz

Rated current : 0.33A

Check rotation direction of the fan, after connecting the motor.

MD.. asynchronous servo motors:

These motors are cooled with a fan driven by a single-phase asynochronous motor.

The fan motor has eight pin type connector.

Connector pin layout (shown from the connecting end):

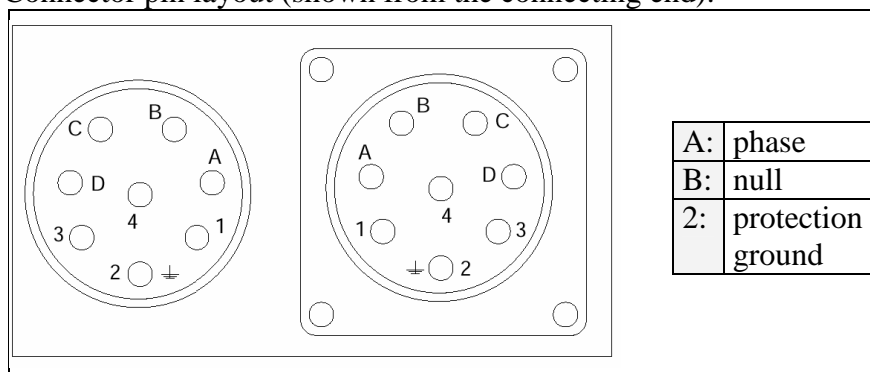

Rated voltage of the motor: 220-240V 50/60Hz

Rated current of the motor: 0.32A